

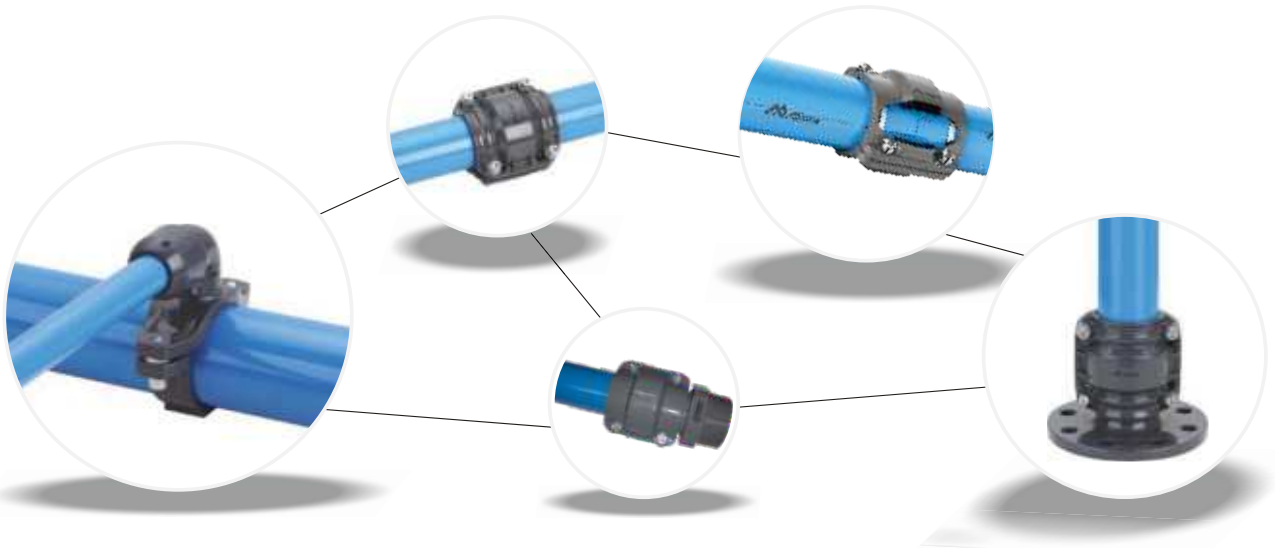

CATALOGUE & INSTALLATION GUIDE

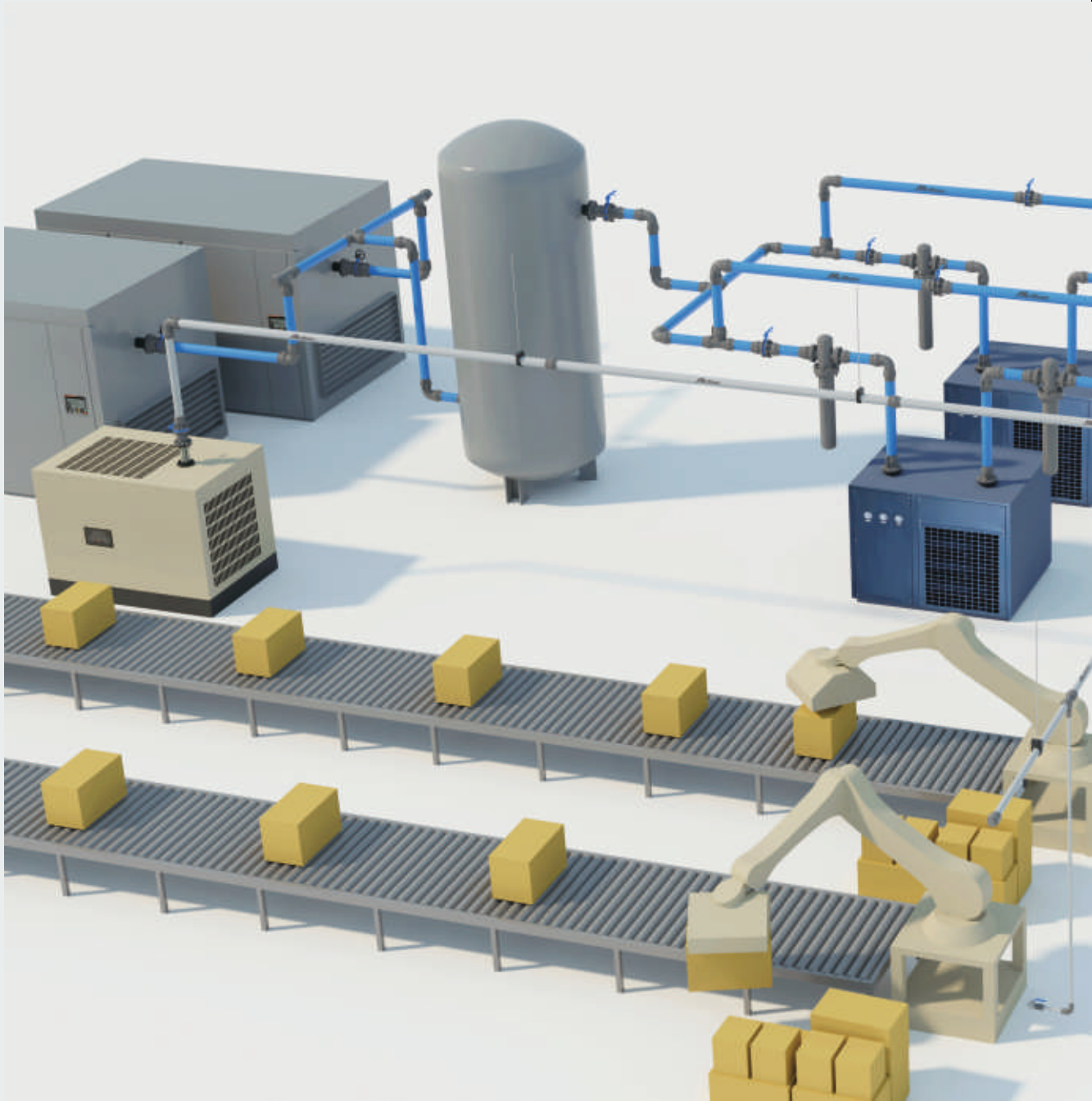



Easy, Simple and quick to connect and install

The pipe and the joints can be assembled quickly without any preparation. Quick assembly, No welding, agglutination or intertwist is needed. No deep training is needed. Light and easy to cut pipes and to operate on site.



Perfect compatibility

AIRPIPE can connect perfectly to the female thread, male thread and flange joints.



Strong, Long life, and beautiful

The material and construction design of AIRPIPE make itself possess the capability to resist corrosion, vibration, hot temperature and any harsh environment. Therefore the air quality is preserved throughout the whole network up to the point of use, protecting the downstream equipment and the manufacturing process.

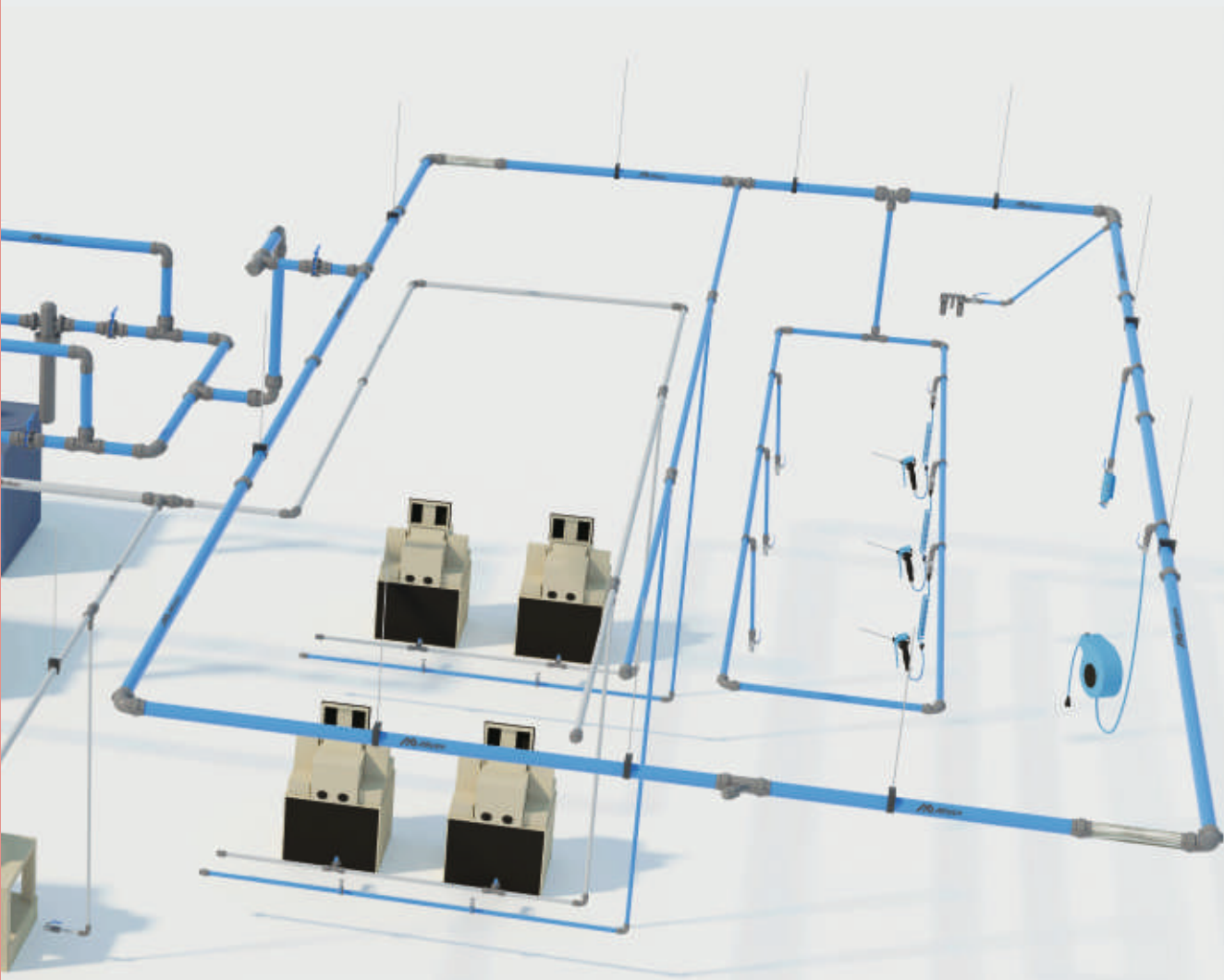

FULL PERFORMANCE COMPRESSED AIR PIPE SYSTEM



Mature technology perfect quality

The compressed air pipe system plays an important role in the entire line of the production. AIRPIPE system adopts the unique technology, proving the high quality compressed air under the suitable pressure environment, reducing the energy cost for the client. The spare parts for AIRPIPE system are more flexible for installation and can meet different design and production requirements from different customers.



Super flexibility

AIRPIPE spare parts can be dismantled and used repeatedly, which can adapt to the changing environment. Shunt device and branch pipelines can be added quickly at any time, which can adapt to the adjustment of the production line. The header slopes in the direction of the airflow towards the low point so that the condensed water can be removed from the pipe system.



Corrosion-Resistant Low Pressure Drop

High quality and smooth inner surface will never rust. It ensures a stable flow of compressed air and guarantees the safety at the point of use. The high performance of "O" sealing ring ensures excellent seal and no leakage. Optimum design and the low friction inner surface eliminate the airflow restriction, reducing the pressure drop efficiently.



Technological innovation of valve

Full volume design makes AIRPIPE energy saving and quick for installation.



AIRpipe presence across India

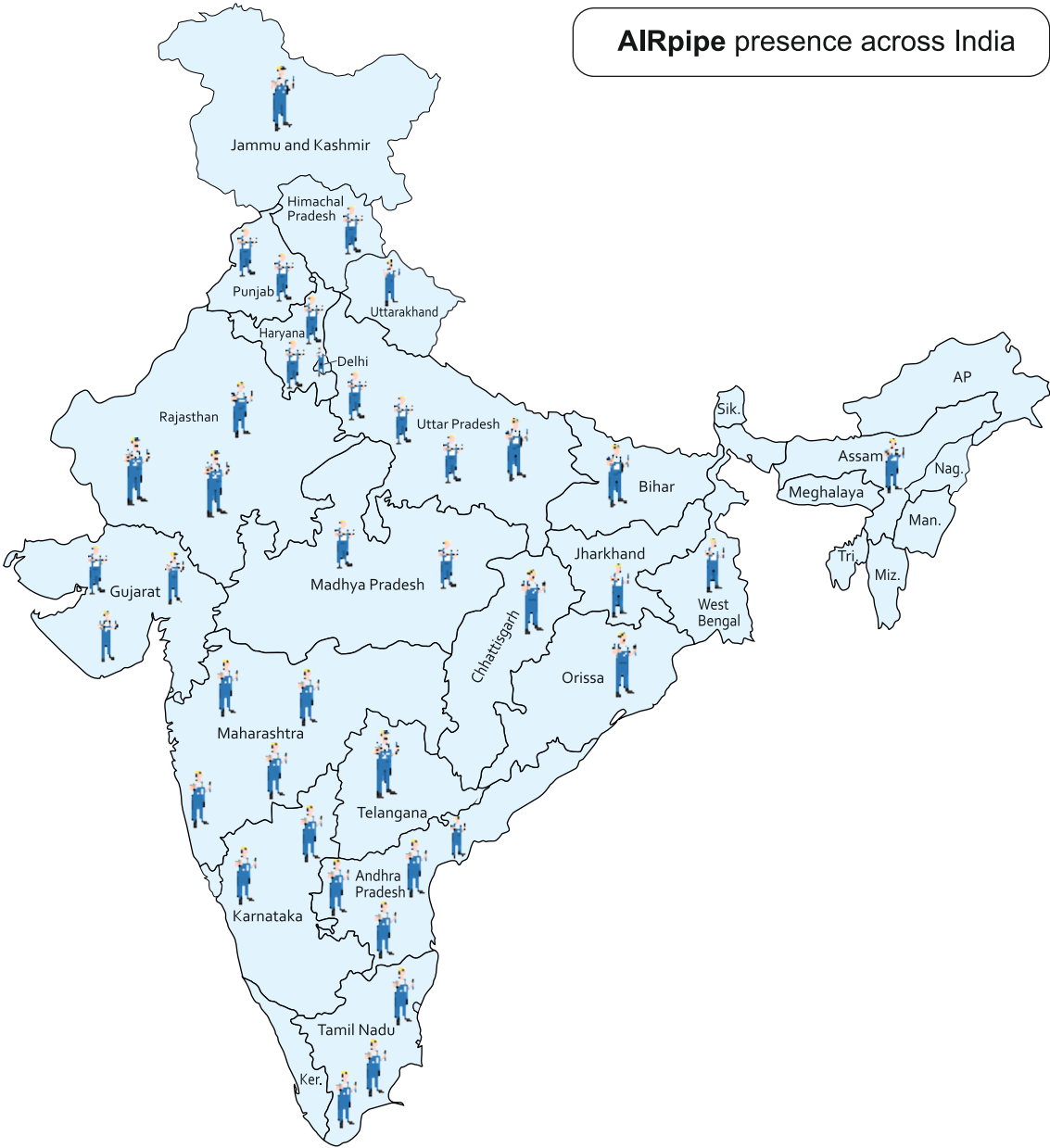

North	West	South	East	Project
<p>E-mail: north@airpipe.in M: +91 9599775242</p> <p>E-mail: north2@airpipe.in M: +91 9599290943</p> <p>E-mail: north3@airpipe.in M: +91 9599441637</p> <p>E-mail: punjab@airpipe.in M: +91 9599441620</p> <p>E-mail: rajasthan@airpipe.in M: +91 9871178502</p> <p>E-mail: lucknow@airpipe.in M: +91 9599693311</p>	<p>E-mail: west@airpipe.in M: +91 9599441097</p> <p>Email: west1@airpipe.in M: +91 8448289450</p> <p>E-mail: gujarat@airpipe.in M: +91 9599494422</p> <p>Email: gujarat1@airpipe.in M: +91 8448391966</p>	<p>E-mail: south1@airpipe.in M: +91 9599600762</p> <p>E-mail: south2@airpipe.in M: +91 9818970106</p> <p>E-mail: chennai@airpipe.in M: +91 8448175369</p> <p>E-mail: hyderabad@airpipe.in M: +91 9870210041</p> <p>E-mail: bangalore@airpipe.in M: +91 8448175391</p>	<p>E-mail: east@airpipe.in M: +91 9599441523</p> <p>E-mail: east1@airpipe.in M: +91 9870291492</p> <p>E-mail: jharkhand@airpipe.in M: +91 7428305454</p> <p>E-mail: guwahati@airpipe.in M: +91 9871178503</p>	<p>projects@airpipe.in M: +91 8448392019</p> <p>E-mail: projects1@airpipe.in M: +91 9650395007</p> <p>Customer Support</p> <p>E-mail: sc@airpipe.in M: +91 9599290941</p> <p>E-mail: ccs@airpipe.in M: +91 7303640036</p> <p>E-mail: warehouse@airpipe.in M: +91 9599597955</p> <p>E-mail: warehouse1@airpipe.in M: +91 9289139644</p>

Warranty and Certifications



10 Year Limited Warranty:

- AIRpipe warrants its products to be free of defects in material and workmanship for a period of ten years from the date of product purchase. No other warranties, express or implied are made by AIRpipe . This limitation explicitly excludes any implied warranty of merchantability or fitness for a particular purpose. The sole remedy for breach of this warranty of material and workmanship or for negligence in manufacture or design is limited to replacement or repair, at the sole discretion of AIRpipe . In no event shall AIRpipe , it's parent, and sister companies be liable for indirect, special, incidental or consequential damages of any kind. No allowance will be made for repairs made by the purchaser.
- AIRpipe does not warrant the design, assembly or installation of the system, but only the components listed within AIRpipe LOGO. AIRpipe is not responsible for improper assembly, installation, or for any modifications of the product.

The warranty is void upon

- failure to follow assembly or installation guidelines;
- alteration, misuse or abuse of, or damage to the products;
- operation beyond the design range, excessive pressure, stress, or mishandling in any way;
- use other than for the intended purpose or in a manner other than specified by AIRpipe .

Engineering standards:

- ASME B31.1 & B31.3
- 6063 T5
- UL94HB
- UL94V-2
- TUV
- CE & EN
- PED 2014/68/EU
- TS
- ASTM B241, EN755-8, GB/T4437.1-2000, JIS H4080

Certifications and Compliances:

- ISO 9001
- ISO 14001
- ISO 8573-1
- ASME, UL, TUV, CRN, CE, EN and TS



Grab Ring Clamping Style Connection
DN20 - DN50mm

- Metal clamshell union connector, quick install & reassembly.
- Grab ring with surface contact, no shrinking on inner diameter.
- Surface contact, active concentric sealing, leak free.
- Superior reliability & longevity.

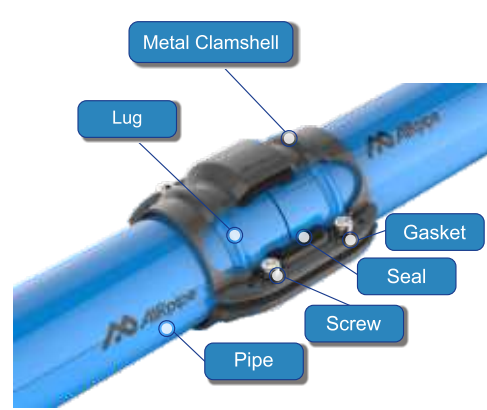

Lugged Ring Clamping Style Connection
DN63 - Dn200mm

- Metal clamshell union connector, quick install & reassembly.
- Convex ring, no shrinking on inner diameter.
- Surface contact, active concentric sealing, leak free.
- Seal protected gasket, guarantee lifespan.
- Superior reliability & longevity.

CONTENT

Rigid Aluminium Pipe		05
Connector/ Elbow & Tee		06
Reducing Tee		08
Reducing Connector & End Cap		09
Adaptor		10
Quick Drop		12
Valve		13
Flange		15
Flexible Hose		17
Fixture Accessories		18
Bracket		19
Tool		23
Important Installation Guide		25
Pneumatic Accessories		38

Technical Specifications

Suitable fluids	Max. Working pressure	Vacuum
<ul style="list-style-type: none"> Compressed air (dry, wet, lubricated) Vacuum Inert gases (including Argon, Helium, Nitrogen, CO2 mixes) 	<ul style="list-style-type: none"> Max. working pressure: 16bar. *(Max. working pressure for DN200 is 13bar.) 	<ul style="list-style-type: none"> Vacuum: 1mbar (absolute pressure)
Resistance to	Recyclability	
<ul style="list-style-type: none"> Corrosion Aggressive environments Mechanical shocks Thermal variations Ultraviolet (U.V.) Compressor oil carry over (mineral/synthetic) 	<ul style="list-style-type: none"> 100% recyclable. 	

PRODUCTS



AIRPIPE	DN20 3/4"	DN25 1"	DN40 1 1/2"	DN50 2"	DN63 2 1/2"	DN80 3"	DN100 4"	DN150 6"	DN200 8"
Aluminum Pipe(2.9m/5.8m)	•	•	•	•	•	•	•	•	•
S Bend	•	•							
Pipe Clip	•	•	•	•	•	•	•	•	•
Gasket	•	•	•	•	•				

AIRPIPE	DN20 3/4"	DN25 1"	DN40 1 1/2"	DN50 2"	DN63 2 1/2"	DN80 3"	DN100 4"	DN150 6"	DN200 8"
Pipe to Pipe connector	•	•	•	•	•	•	•	•	•
45° Elbow	•	•	•	•	•	•	•	•	•
90° Elbow	•	•	•	•	•	•	•	•	•
Tee	•	•	•	•	•	•	•	•	•
Reducer Tee		•	•	•	•	•	•	•	•
Reducer connector		•	•	•	•	•	•	•	•
End Cap	•	•	•	•	•	•	•	•	•
Nipple Socket (Male thread)	•	•	•	•	•				
Nipple Socket (Female thread)	•	•	•	•	•				
Quick Drop		•	•	•	•	•	•	•	•
Quick Plug Valve	•	•	•	•	•	•	•	•	•
Flange connector					•	•	•	•	•
Flange with Female Thread		•	•	•	•	•	•	•	
Hose	•	•	•	•	•	•	•	•	•

Rigid aluminum pipe

- Clean air certified (ISO 8573-1)
- Optimum flow performance
- Lightweight
- High quality powder coated exterior
- Extruded marine grade aluminum
- Suitable for Compressed air, oil-free or lubricated, vacuum, and inert gases (Nitrogen, Argon, Helium, CO₂)

- Max. working pressure: 16bar
Max. working pressure for DN 200 is 13bar
- Vacuum: 1mbar (absolute pressure)
- Working temperature: -4°F up to +176°F
-20°C up to +80°C

Aluminum alloy Pipe : ● Standard

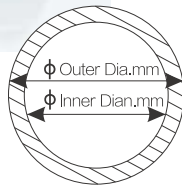

AIRPIPE		Diameter	OD(mm)	ID(mm)	L(M)
Old Part No.	New Part No.				
2009 1000 00	30100010001	20	20.1	17.5	5.8 /6
2009 1063 00		20	20.1	17.5	2.9 /3
2009 2000 00	30100020001	25	25.1	22.5	5.8 /6
2009 2063 00	30100020101	25	25.1	22.5	2.9 /3
2009 4000 00	30100040001	40	40.1	36.5	5.8 /6
2009 4063 00	30100040101	40	40.1	36.5	2.9 /3
2009 5000 00	30100050001	50	50.1	45.7	5.8 /6
2009 5063 00	30100050101	50	50.1	45.7	2.9 /3
2014 6000 00	30100060001	63	67.6	63	5.8 /6
2014 6063 00	30100060101	63	67.6	63	2.9 /3
2014 7000 00	30100070001	80	84.8	80.0	5.8 /6
2014 7063 00	30100070101	80	84.8	80.0	2.9 /3
2009 8000 00	30100080001	100	101.8	96.8	5.8 /6
2009 8063 00	30100080101	100	101.8	96.8	2.9 /3
2009 9000 00	30100090001	150	153	147.5	5.8 /6
2009 9063 00	30100090101	150	153	147.5	2.9 /3
2012 A000 00	30100100001	200	205	198.6	5.8
2012 A063 00	30100110101	200	205	198.6	2.9

Aluminum alloy Pipe: ●●●● (as per required)



2009 1062 00	30100010002	20	20.1	17.5	5.8 /6
2009 1064 00	30100010102	20	20.1	17.5	2.9 /3
2009 2062 00	30100020002	25	25.1	22.5	5.8 /6
2009 2064 00	30100020102	25	25.1	22.5	2.9 /3
2009 4062 00	30100040002	40	40.1	36.5	5.8 /6
2009 4064 00	30100040102	40	40.1	36.5	2.9 /3
2009 5062 00	30100050002	50	50.1	45.7	5.8 /6
2009 5064 00	30100050102	50	50.1	45.7	2.9 /3
2014 6062 00	30100060002	63	67.6	63	5.8 /6
2014 6064 00	30100060102	63	67.6	63	2.9 /3
2014 7062 00	30100070002	80	84.8	80.0	5.8 /6
2014 7064 00	30100070102	80	84.8	80.0	2.9 /3
2009 8062 00	30100080002	100	101.8	96.8	5.8 /6
2009 8064 00	30100080102	100	101.8	96.8	2.9 /3
2009 9062 00	30100090002	150	153	147.5	5.8 /6
2009 9064 00	30100100102	150	153	147.5	2.9 /3
2012 A062 00	30100100002	200	205	198.6	5.8
2012 A064 00	30100110102	200	205	198.6	2.9

S Bend



AIRPIPE		Diameter	a	b
Old Part No.	New Part No.			
2009 1001 00	30101010001	20	170	0.5
2009 2001 00	30101020001	25	120	0.5

*S bend is often used to fix drop legs closer to the wall when the main ring is installed further away from the wall.

Connector

Features

- AIRPIPE provides various connectors to break the limitation of the conventional pipe and fittings in the construction structure.
- Quick connecting
- Full volume flow design
- To be able to dismantle, reassemble and reuse.
- Non-flammable materials
- The whole piping can keep the same flow diameter

Aluminum pipe to pipe Connector

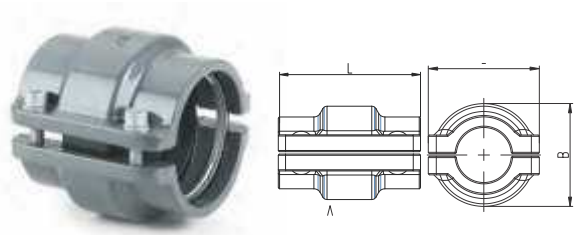

AIRPIPE		Diameter	L	A	B
Old Part No.	New Part No.				
AE 15 1002 00	30202010001	20	59	36	41
AE 15 2002 00	30202020001	25	59	42	44
AE 15 4002 00	30202040001	40	78	69	60
AE 15 5002 00	30202050001	50	79	80	74

Aluminum pipe to pipe Connector

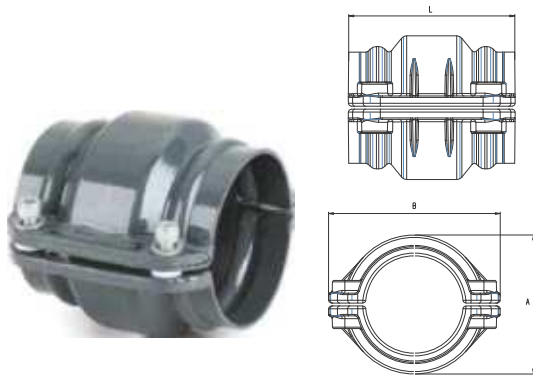

AIRPIPE		Diameter	L	A	B
Old Part No.	New Part No.				
2016 6002 00	30202060105	63	114	97	113
2017 7002 00	30202070108	80	114	114	137
2017 8002 00	30202080108	100	140	131	151
2018 9002 00	30202100105	150	146	184	226
2018 A002 00	30202110105	200	134	236	280
	30202120201	250	111	307.5	347.5

Equal 90° Elbow

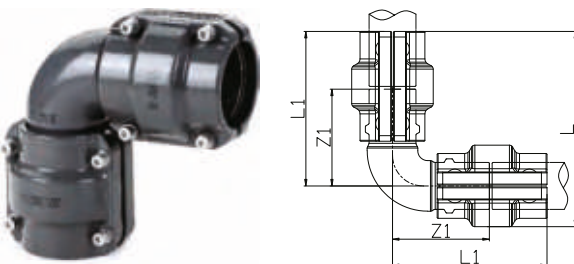

AIRPIPE		Nominal Diameter	L1	L	Z1
Old Part No.	New Part No.				
AE15 1003 99	30203010002	20	80	100	61
AE15 2003 99	30203020002	25	83	105	67
AE15 4003 99	30203040002	40	109	139	91
AE15 5003 99	30203050002	50	115	152	101

Aluminum 90° Elbow

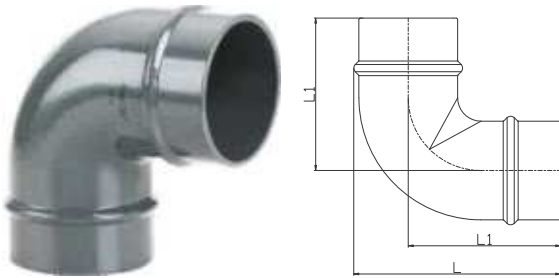

AIRPIPE		Diameter	L	L1
Old Part No.	New Part No.			
2014 6003 00	30203060001	63	143	105
2014 7003 00	30203070001	80	156	110
2012 8003 00	30203080001	100	194	140
2012 9003 00	30203100001	150	265	185
2012 A003 00	30203110001	200	313	208
	30203120001	250	558	418

Aluminum 45° Elbow

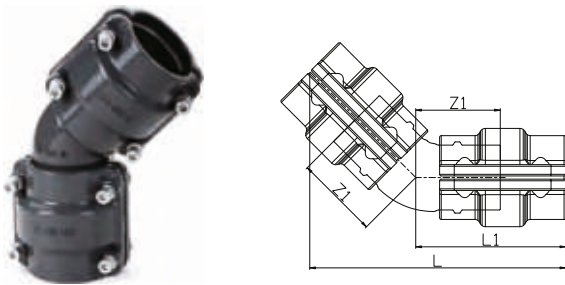

AIRPIPE		Nominal Diameter	L	L1	Z1
Old Part No.	New Part No.				
AE15 1004 99	30204010002	20	118	70	39
AE15 2004 99	30204020002	25	119	71	40
AE15 4004 99	30204040002	40	159	92	52
AE15 5004 99	30204050002	50	162	95	54

Equal 45° Elbow

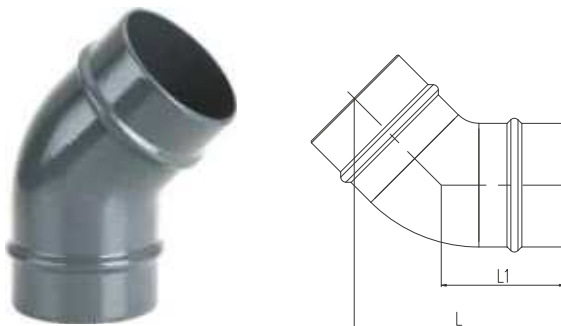

AIRPIPE		Diameter	L	L1
Old Part No.	New Part No.			
2015 6004 00	30204060001	63	137	80
2015 7004 00	30204070001	80	145	85
2015 8004 00	30204080001	100	180	105
2015 9004 00	30204100001	150	215	126
2015 A004 00	30204110001	200	230	135
	30204120001	250	373.5	219

Equal Tee

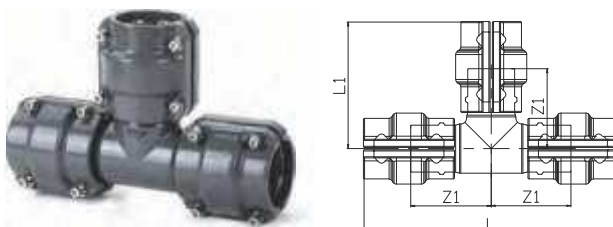

AIRPIPE		Nominal Diameter	L	L1	Z1
Old Part No.	New Part No.				
AE15 1005 99	30205010002	20	160	80	49
AE15 2005 99	30205020002	25	166	83	52
AE15 4005 99	30205040002	40	218	109	69
AE15 5005 99	30205050002	50	230	115	74

Aluminum Equal Tee

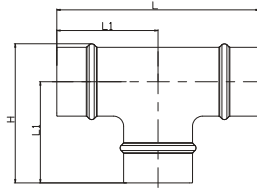

AIRPIPE		Diameter	L	L1	H
Old Part No.	New Part No.				
2014 6005 00	30205060001	63	200	100	137
2014 7005 00	30205070001	80	220	110	156
2014 8005 00	30205080001	100	262	131	186
2014 9005 00	30205100001	150	332	170	250
2012 A005 00	30205110001	200	375	187.5	293
	30205120001	250	446	233	

Reducing Tee

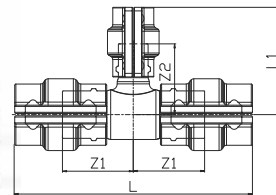

AIRPIPE		Nominal Diameter	L	Z1	Z2	L1
Old Part No.	New Part No.					
AE15 2107 99	30207020102	25X20	160	50	51	80
AE15 4207 99	30207040202	40X25	200	61	60	90
AE15 5207 99	30207050201	50X25	220	70	71	101
AE15 5407 99	30207050402	50X40	220	70	74	114

Reducing Tee

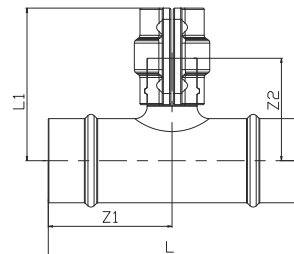

AIRPIPE		Nominal Diameter	L	Z1	L1	Z2
Old Part No.	New Part No.					
AE15 6407 99	30207060402	63x40	200	100	122	83
AE15 6507 99	30207060502	63x50	200	100	123	83
AE15 7407 99	30207070402	80x40	190	100	132	92
AE15 7507 99	30207070502	80x50	200	106	133	92
AE15 8507 99	30207080502	100x50	226	118	141	100

*Use (2) union connectors.

Aluminum Reducing Tee

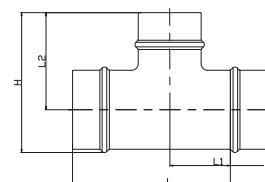

AIRPIPE		Diameter	L	L1	L2	H
Old Part No.	New Part No.					
2014 7607 00	30207070601	80X63	210	105	105	151
2014 8607 00	30207080602	100X63	236	118	118	172
2014 8707 00	30207080702	100X80	246	123	121	175
2014 9607 00	30207100601	150X63	242	121	150	230
2014 9707 00	30207100701	150X80	226	131	147	227
2014 9807 00	30207100801	150X100	272	136	162	242
2014 A607 00	30207110601	200X63	240	120	170	276
2014 A707 00	30207110701	200X80	256	128	171	276
2012 A807 00	30207110801	200X100	276	138	182	288
2014 A907 00	30207111001	200X150	344	172	182	288
	30207121101	250X200	282	191	252.5	

Reducing Pipe to Pipe Connector

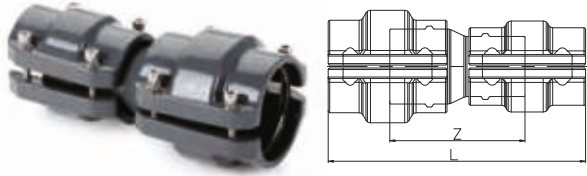

AIRPIPE		Nominal Diameter	L	Z
Old Part No.	New Part No.			
AE15 2121 99	30221020102	25x20	130	67
AE15 4221 99	30221040202	40x25	156	84
AE16 5221 99	30221050202	50x25	160	86
AE15 5421 99	30221050402	50x40	172	91

Reducing Pipe to Pipe Connector

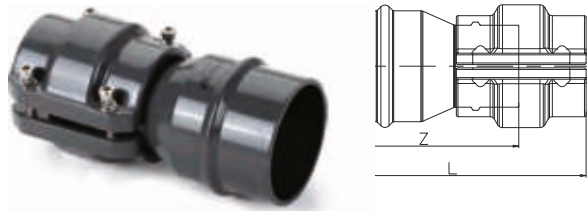

AIRPIPE		Nominal Diameter	L	Z
Old Part No.	New Part No.			
AE16 6421 99	30221060402	63x40	156	116
AE15 6521 99	30221060502	63x50	157	117
AE15 7521 99	30221070502	80x50	158	117

*Use a union connector.

Aluminum Reducing Pipe to Pipe Joint

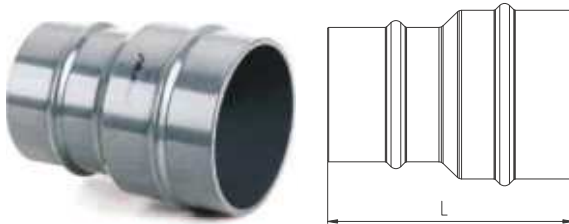

AIRPIPE		Diameter	L
Old Part No.	New Part No.		
2014 7621 00	30221070601	80X63	126
2014 8621 00	30221080601	100X63	152
2014 8721 00	30221080701	100x80	141
2014 9721 00	30221100701	150X80	155
2012 9821 00	30221100801	150X100	172
2012 A921 00	30221111001	200X150	170
	30221121101	250X200	368

End Cap

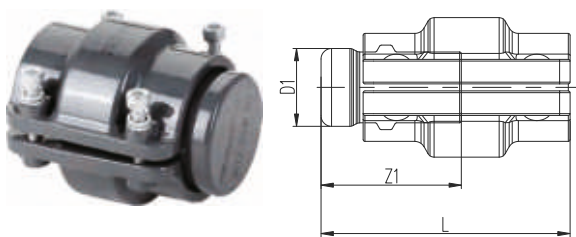

AIRPIPE		Nominal Diameter	L	D1	Z1
Old Part No.	New Part No.				
AE15 1006 99	30206010002	20	70	22	40
AE15 2006 99	30206020002	25	70	27	40
AE15 4006 99	30206040002	40	90	42	49
AE15 5006 99	30206050002	50	91	52	50

Aluminum End Cap

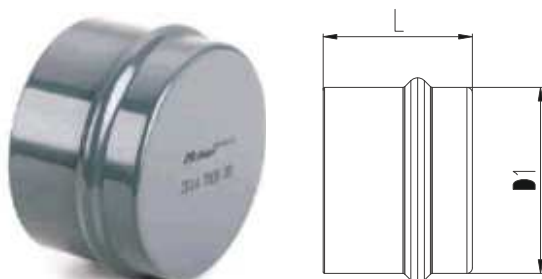

AIRPIPE		Diameter	L	D1
Old Part No.	New Part No.			
2014 6006 00	30206060001	63	54	68
2014 7006 00	30206070001	80	55	85,4
2012 8006 00	30206080001	100	70	101,8
2012 9006 00	30206100001	150	70	153
2012A006 00	30206110001	200	70	205
	30206120001	250	140	273

Aluminum 90° Elbow (Male Thread)

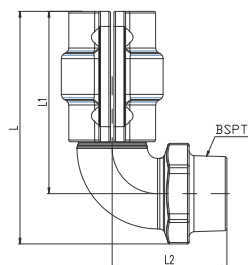

AIRPIPE		Diameter	L	L1	L2	Thread size (BSP)
Old Part No.	New Part No.					
AE15 1115 99	30215010101	20	95	79	49	3/4"
AE15 1015 99	30215010001	20	95	79	49	1/2"
AE15 2215 99	30215020201	25	102	82	52	1"
AE15 2015 99	30215020001	25	102	82	52	1/2"
AE15 4415 99	30215040401	40	141	109	69	1-1/2"
AE15 5515 99	30215050501	50	151	114	74	2"

Note: Be suitable for connecting with the outlet of Air Compressor Cold dryer and strainer.etc.

Aluminum 90° Elbow (Female Thread)

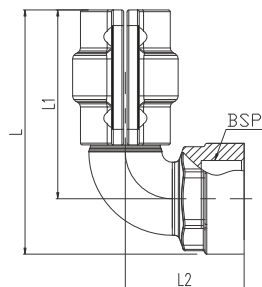

AIRPIPE		Diameter	L	L1	L2	Thread size (BSP)
Old Part No.	New Part No.					
AE15 1113 99	30213010101	20	95	79	49	3/4"
AE15 1013 99	30213010001	20	95	79	49	1/2"
AE15 2213 99	30213020201	25	102	82	52	1"
AE15 2013 99	30213020001	25	102	82	52	1/2"
AE15 4413 99	30213040401	40	141	109	69	1-1/2"
AE15 5513 99	30213050501	50	151	114	74	2"

Note: Be suitable for connecting with the outlet of Air Compressor and Cold dryer.

Female Threaded Adapter

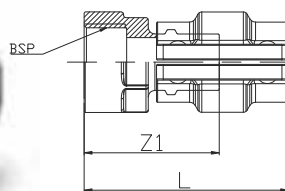

AIRPIPE		Nominal Diameter	L	BSP	Z1
Old Part No.	New Part No.				
AE16 1019 99	30219010002	20	88	1/2"	57
AE15 1119 99	30219010102	20	88	3/4"	58
AE16 2019 99	30219020002	25	90	1/2"	59
AE15 2219 99	30219020202	25	90	1"	60
AE15 4419 99	30219040402	40	119	1-1/2"	78
AE15 5519 99	30219050502	50	120	2"	79

Aluminum Nipple Socket (Female Thread)

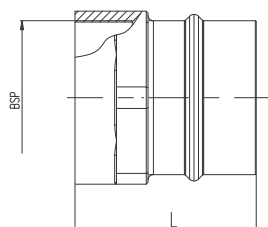

AIRPIPE		Diameter	L	Thread size (BSP)
Old Part No.	New Part No.			
2014 6619 00	30219060601	63	93	2-1/2"
2014 7719 00	30219070701	80	100	3"

Male Threaded Adapter

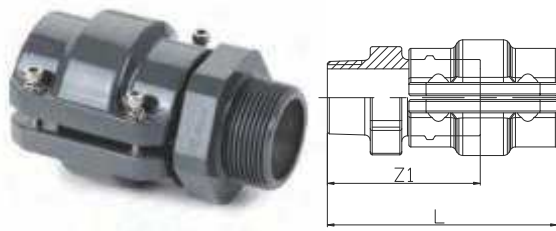

AIRPIPE		Nominal Diameter	L	Z1	BSP
Old Part No.	New Part No.				
AE15 1017 99	302170100 02	20	90	59	½"
AE15 1117 99	30217010102	20	91	60	¾"
AE16 2017 99	30217020002	25	92	60	½"
AE15 2117 99	30217020102	25	93	60	¾"
AE15 2217 99	30217020202	25	93	62	1"
AE15 4217 99	30217040202	40	119	78	1"
AE15 4317 99	30217040302	40	122	81	1-¼"
AE15 4417 99	30217040402	40	122	81	1-½"
AE17 4517 99	30217040501	40	122	81	2"
AE15 5417 99	30217050402	50	122	81	1-½"
AE15 5517 99	30217050502	50	126	85	2"

Aluminum Nipple Socket (Male Thread)

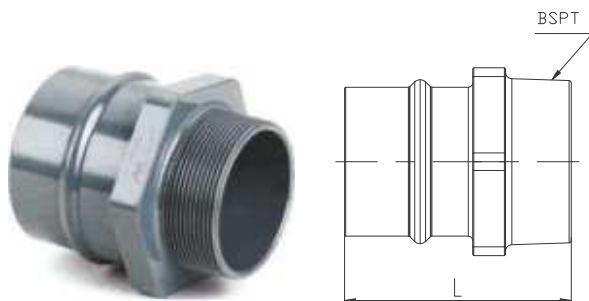

AIRPIPE		Nominal Diameter	L	Thread size (BSP)
Old Part No.	New Part No.			
2014 6517 00	30217060501	63	99	2"
2014 6617 00	30217060601	63	105	2-½"
2014 7617 00	30217070601	80	107	2-½"
2014 7717 00	30217070701	80	110	3"

Lateral Equal Tee

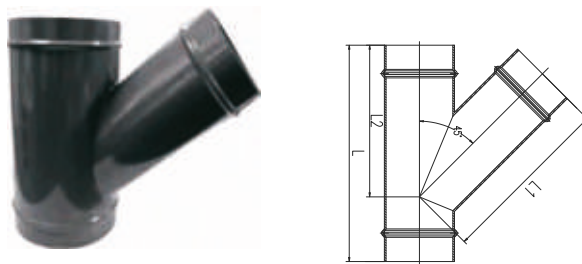

AIRPIPE		Nominal Diameter	L	L1	L2
Old Part No.	New Part No.				
2016 6009 00	30209060001	63	238	184	163
2016 7009 00	30209070001	80	262	211	184
2016 8009 00	30209080001	100	305	246	213
2016 9009 00	30209100001	150	385	340	280
2016 A009 00	30209110001	200	459	400	347

*Use (3) union connectors.

Lateral Reducing Tee

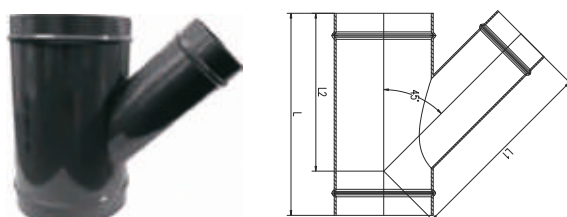

AIRPIPE		Nominal Diameter	L	L1	L2
Old Part No.	New Part No.				
2016 8712 00	30212080701	100x80	282	226	202
2016 9712 00	30212100701	150x80	292	276	235
2016 9812 00	30212100801	150x100	312	300	244
2016 A812 00	30212110801	200x100	320	339	275
2016A912 00	30212111001	200x150	394	377	312

*Use (3) union connectors.

Quick Drop

Features

- The new generation quick drop can be used horizontally or vertically, connecting to a rigid pipe or a hose.
- High Volume Flow
- The complete water trap ensures the water will not enter the downstream branch
- It can be installed quickly. No need to cut the pipes.

Aluminum Quick Drop

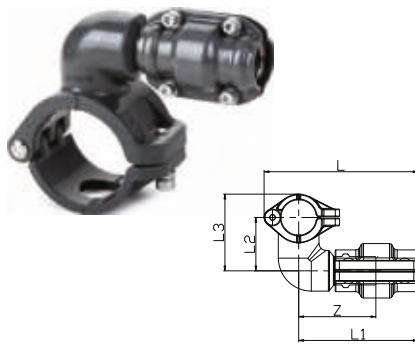

AIRPIPE		Nominal Diameter	L	L1	Z	L2	L3	Drill
Old Part No.	New Part No.							
AE18 2110 99	302 10 0201 04	25x20	110	85	55	38	55	16
AE18 2210 99	302 10 0202 03	25x25	110	85	55	38	55	16
AE18 4110 99	302 10 0401 04	40x20	125	91	61	45	70	22
AE18 4210 99	302 10 0402 04	40x25	125	91	61	45	70	22
AE17 5110 99	302 10 0501 01	50x20	129	89	59	54	84	25
AE17 5210 99	302 10 0502 01	50x25	129	89	59	54	84	25
AE17 6110 99	302 10 0601 01	63x20	152	89	59	71	112	25
AE17 6210 99	302 10 0602 01	63x25	152	89	59	71	112	25
AE17 7110 99	302 10 0701 01	80x20	158	89	59	77	127	25
AE17 7210 99	302 10 0702 01	80x25	158	89	59	77	127	25
AE17 8110 99	302 10 0801 01	100x20	154	83	53	97	154	25
AE17 8210 99	302 10 0802 01	100x25	154	83	53	97	154	25
AE17 9110 99	302 10 1001 01	150x20	202	82	52	123	204	25
AE17 9210 99	302 10 1002 01	150x25	202	82	53	123	204	25
AE17 A210 99	302 10 1102 01	200x25	256	84	55	149	267	25

Aluminum Quick Drop

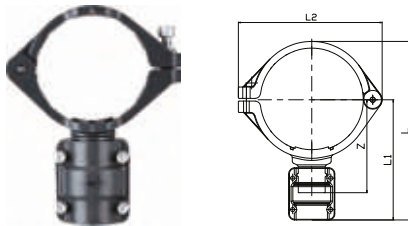

AIRPIPE		Nominal Diameter	L	L1	L2	Z	Drill
Old Part No.	New Part No.						
AE15 8410 99	302 10 0804 01	100x40	204	134	162	104	38
AE15 9410 99	302 10 1004 01	150x40	267	180	215	150	51
AE15 9510 99	302 10 1005 01	150x50	255	181	215	151	51
AE15 A410 99	302 10 1104 01	200x40	329	206	269	176	51
AE15 A510 99	302 10 1105 01	200x50	330	207	269	177	51

Note: The products can be replaced with Reducing Tee (BA) marking "8"

Aluminum Quick Drop-Female Thread

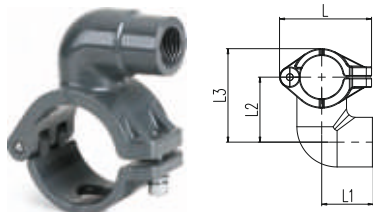

AIRPIPE		DN x BSP	L	L1	L2	L3	Drill
Old Part No.	New Part No.						
AE18 2011 00	302 11 0200 03	25x1/2"	54	30	38	50	16
AE18 4011 00	302 11 0400 03	40x1/2"	72	42	45	70	22
AE18 4111 00	302 11 0401 03	40x3/4"	72	42	45	70	22
2017 5011 00	302 11 0500 01	50x1/2"	83	46	54	84	25
2017 5111 00	302 11 0501 01	50x3/4"	83	47	54	84	25

Aluminum Quick Drop-Female Thread

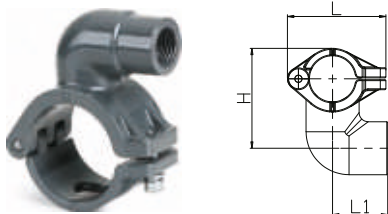

AIRPIPE		DN	BSP	L1	L	H	Drill
Old Part No.	New Part No.						
2017 6011 00	302 11 0600 01	63	1/2"	65	126	112	25
2017 6111 00	302 11 0601 01	63	3/4"	78	126	112	25
2017 7011 00	302 11 0700 01	80	1/2"	65	138	127	25
2017 7111 00	302 11 0701 01	80	3/4"	78	138	127	25
2017 8011 00	302 11 0800 01	100	1/2"	54	170	150	25
2017 9011 00	302 11 1000 01	150	1/2"	55	219	201	25

Quick Drop(Straight Female)



AIRPIPE Part No.	DESCRIPTION OF GOODS
30211050005	QUICK DROP STRAIGHT THREAD FEMALE, DN50-1/2"
30211050105	QUICK DROP STRAIGHT THREAD FEMALE, DN50-3/4"
30211060004	QUICK DROP STRAIGHT THREAD FEMALE, DN63-1/2"
30211060104	QUICK DROP STRAIGHT THREAD FEMALE, DN63-3/4"
30211070004	QUICK DROP STRAIGHT THREAD FEMALE, DN80-1/2"
30211070104	QUICK DROP STRAIGHT THREAD FEMALE, DN80-3/4"
30211080005	QUICK DROP STRAIGHT THREAD FEMALE, DN100-1/2"
30211080102	QUICK DROP STRAIGHT THREAD FEMALE, DN100-3/4"
30211100005	QUICK DROP STRAIGHT THREAD FEMALE, DN150-1/2"
30211100102	QUICK DROP STRAIGHT THREAD FEMALE, DN150-3/4"
30211110002	QUICK DROP STRAIGHT THREAD FEMALE, DN200-1/2"
30211110102	QUICK DROP STRAIGHT THREAD FEMALE, DN200-3/4"

Valve

Features

- AIRPIPE ball valve and butterfly valve can be installed in the piping and some important position such as outlet of compressor and upstream of pneumatic tools. Good for the separation, adjustment and maintenance.
- Quick install
- Provide a range of male threaded valve to better connect the system.
- The type of Thread can be BSP or NPT.

Quick plug ball valve (Female Thread)



AIRPIPE		DESCRIPTION OF GOODS
Old Part No.	New Part No.	
AI15 1151 99	30451010101	BRASS VALVE, DN20-TWO 1/2" FEMALE THREAD
AI15 1251 99	30451010201	BRASS VALVE, DN20-1/2" FEMALE THREAD
AI15 2151 99	30451020101	BRASS VALVE, DN25-TWO 1/2" FEMALE THREAD
AI15 2251 99	30451020201	BRASS VALVE, DN25-1" FEMALE THREAD
AI15 2451 99	30451020401	BRASS VALVE, DN25-1/2" FEMALE THREAD
AI15 4451 99	30451040401	BRASS VALVE, DN40-1-1/2" FEMALE THREAD
AI15 5551 99	30451050501	BRASS VALVE, DN50-2" FEMALE THREAD

Quick plug ball valve (male Thread)



AIRPIPE		DESCRIPTION OF GOODS
Old Part No.	New Part No.	
AI15 1351 99	30451010301	BRASS VALVE, DN20-3/4" MALE THREAD
AI15 2351 99	30451020301	BRASS VALVE, DN25-1" MALE THREAD
AI15 4351 99	30451040301	BRASS VALVE, DN40-1-1/2" MALE THREAD
AI15 5351 99	30451050301	BRASS VALVE, DN50-2" MALE THREAD

Quick plug ball valve (Two head /Female Thread)



AIRPIPE		DESCRIPTION OF GOODS
Old Part No.	New Part No.	
AI16 1551 99	30451010501	BRASS VALVE, DN20-TWO 1/2" FEMALE THREAD, 75°
AI16 2551 99	30451020501	BRASS VALVE, DN25-TWO 1/2" FEMALE THREAD, 75°

Non-Valved Wall Bracket



AIRPIPE		DESCRIPTION OF GOODS
Old Part No.	New Part No.	
AE 17 1123 99	30223010101	DN20, ONE-PORT 1/2", FEMALE, 45°
AE17 2123 99	30223020101	DN25, ONE-PORT 1/2", FEMALE, 45°
AE17 1023 99	30223010001	DN20, TWO-PORT 1/2", FEMALE, 45°
AE17 2023 99	30223020001	DN25, TWO-PORT 1/2", FEMALE, 45°

Quick plug ball valve



AIRPIPE		DESCRIPTION OF GOODS
Old Part No.	New Part No.	
AI15 1051 99	30451010001	BRASS VALVE, DN20
AI15 2051 99	30451020001	BRASS VALVE, DN25
AI15 4051 99	30451040001	BRASS VALVE, DN40
AI15 5051 99	30451050001	BRASS VALVE, DN50

Ball Valve



- Ball valve (Male Thread)
- Ball valve (Female Thread)



- Ball valve (Male Thread--Female Thread)

New Threaded Ball Valve



- Threaded male Ball Valve DN6351 - 2 1/2"
- Threaded Female Ball Valve DN6651 - 2 1/2"

Butterfly Valve



- Dn63 Ball Valve

Swing Check Valve



Lock Ball Valve



AIRPIPE		D1 (BSP)	D2 (BSP)	Connector
Old Part No.	New Part No.			
AI 15 0073	00 30473000001	1/2"	1/2"	Female Thread
AI 15 0173	00 30473010001	3/4"	3/4"	Female Thread
AI 151073	00 30473000101	1/2"	1/2"	Male Thread
AI 15 1173	00 30473010101	3/4"	3/4"	Male Thread
AI 15 0273	00 30473000201	1/2"	1/2"	Male Thread--Female Thread
AI 15 1273	00 30473010201	3/4"	3/4"	Male Thread--Female Thread
AI 15 2073	00 30473020001	1"	1"	Female Thread
AI 15 4073	00 30473040001	1-1/2"	1-1/2"	Female Thread
AI 15 5073	00 30473050001	2"	2"	Female Thread

AIRPIPE		DESCRIPTION OF GOODS
Old Part No.	New Part No.	
2018 6351	00 30451060301	Threaded Male Ball Valve DN -63 - 2-1/2"
2018 6651	00 30451060601	Threaded Female Ball Valve DN -63 - 2-1/2"

AIRPIPE		Diameter	L1	Material of valve	Remark
Old Part No.	New Part No.				
2015 6051	00 30251060001	63	188	Cast Iron	Need to match two Pipe to Pipe connector
2014 6151	00 30251060101	63	188	Stainless steel	
2015 7051	00 30251070001	80	210	Cast Iron	
2014 7151	00 30251070101	80	210	Stainless steel	
2015 8051	00 30251080001	100	236	Cast Iron	
2015 9051	00 30251100001	150	256	Cast Iron	
2015 A051	00 30251110001	200	278	Cast Iron	
2015 8151	00 30251080101	100	236	Stainless steel	
2015 9151	00 30251100101	150	256	Stainless steel	
2012 A151	00 30251110101	200	278	Stainless steel	

AIRPIPE		Diameter	Material of valve	Remark
Old Part No.	New Part No.			
2014 4480	00 30280040001	40	Cast Iron	Quick Plug
2014 5580	00 30280050001	50	Cast Iron	
2014 6680	00 30280060001	63	Cast Iron	Clamp
2014 7780	00 30280070001	80	Cast Iron	
2014 8880	00 30280080001	100	Cast Iron	
2014 9980	00 30280100001	150	Cast Iron	
2015 AA80	00 30280110001	200	Cast Iron	
2014 4481	00 30280040101	40	Stainless steel	Quick Plug
2014 5581	00 30280050101	50	Stainless steel	
2014 6681	00 30280060101	63	Stainless steel	Clamp
2014 7781	00 30280070101	80	Stainless steel	
2014 8881	00 30280080101	100	Stainless steel	
2014 9981	00 30280100101	150	Stainless steel	
2015 AA81	00 30280110101	200	Stainless steel	

Note : Used to stop the air backflow.

AIRPIPE		DESCRIPTION OF GOODS
Old Part No.	New Part No.	
AI15 1052	99 30452010001	LOCK BRASS VALVE, DN20
AI15 2052	99 30452020001	LOCK BRASS VALVE, DN25
AI15 4052	99 30452040001	LOCK BRASS VALVE, DN40
AI15 5052	99 30452050001	LOCK BRASS VALVE, DN50
AI15 1152	99 30452010101	LOCK BRASS VALVE, DN20-TWO 1/2" FEMALE
AI16 1552	99 30452010501	LOCK BRASS VALVE, DN20-1/2", TWO PORTS, FEMALE, 75°
AI15 1252	99 30452010201	LOCK BRASS VALVE, DN20-1/2" FEMALE
AI15 2152	99 30452020101	LOCK BRASS VALVE, DN25-TWO 1/2" FEMALE
AI16 2552	99 30452020501	LOCK BRASS VALVE, DN25-1/2", TWO PORTS, FEMALE, 75°
AI15 2252	99 30452020201	LOCK BRASS VALVE, DN25-1" FEMALE
AI15 2452	99 30452020401	LOCK BRASS VALVE, DN25-1/2" FEMALE
AI15 4452	99 30452040401	LOCK BRASS VALVE, DN40-1 1/2" FEMALE
AI15 5552	99 30452050501	LOCK BRASS VALVE, DN50-2" FEMALE
AI15 1352	99 30452010301	LOCK BRASS VALVE, DN20-3/4" MALE
AI15 2352	99 30452020301	LOCK BRASS VALVE, DN25-1" MALE
AI15 4352	99 30452040301	LOCK BRASS VALVE, DN40-1 1/2" MALE
AI15 5352	99 30452050301	LOCK BRASS VALVE, DN50-2" MALE

*Union connectors included

Flange

Aluminum Flange connector

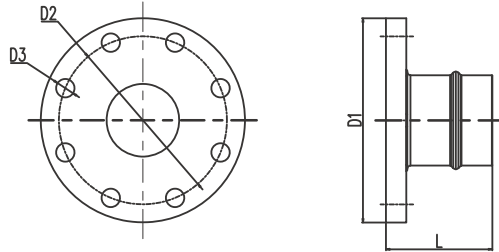

<i>AIRPIPE</i>		Diameter	Flange size	Bolt size	L	D1	D2	D3
Old Part No.	New Part No.							
2014 6170 00	30270060001	63	65	M16	85	185	145	18
2014 7170 00	30270070001	80	80	M16	82	200	160	18
2014 8170 00	30270080001	100	100	M16	92	220	180	18
2014 9170 00	30270100001	150	150	M20	100	285	240	22
2012 A170 00	30270110001	200	200	M20	109	340	295	22
	30370120001	250	250		132	405	362	26

* 8 pieces of flange bolts(7cm) and 1 piece of flange gasket are attached.

Aluminum Reduced Flange Connector

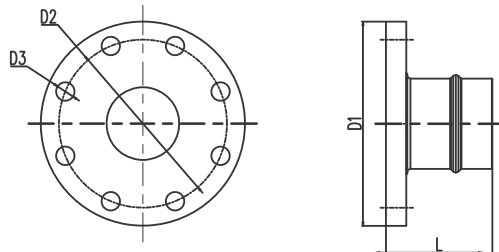

<i>AIRPIPE</i>		Diameter	Flange size	Bolt size	L	D1	D2	D3
Old Part No.	New Part No.							
2014 7671 00	30271070601	63	80	M16	85	200	160	18
2014 8671 00	30271080601	63	100	M16	87	220	180	18
2014 6771 00	30271060701	80	65	M16	87	185	145	18
2014 8771 00	30271080701	80	100	M16	84	220	180	18
2014 0771 00	30271090701	80	125	M16	84	250	210	18
2014 7871 00	30271070801	100	80	M16	92	200	160	18
2014 0871 00	30271090801	100	125	M16	92	250	210	18
2014 9871 00	30271100801	100	150	M20	92	285	240	22
2014 0971 00	30271091001	150	125	M16	100	250	210	18
	30371121101	250	200		132	405	362	26

* 8 pieces of flange bolts(7cm) and 1 piece of flange gasket are attached.

Flange with Female Thread

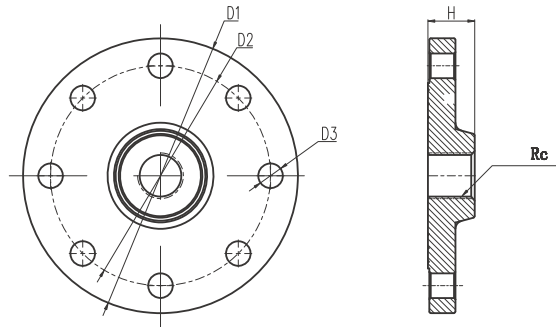

AIRPIPE		Diameter	Rc(Female thread)z	Bolt size	D1	D2	D3	H
Old Part No.	New Part No.							
2009 2270 00	30270020201	25	1"	M12	115	85	14	28
2009 4470 00	30270040401	40	1-1/2"	M16	150	110	18	32
2009 5570 00	30270050501	50	2"	M16	165	125	18	34
2009 6270 00	30270060201	65	1"	M16	185	145	18	32
2009 6470 00	30270060401	65	1-1/2"	M16	185	145	18	32
2009 6570 00	30270060501	65	2"	M16	185	145	18	32
2009 7270 00	30270070201	80	1"	M16	200	160	18	34
2009 7470 00	30270070401	80	1-1/2"	M16	200	160	18	34
2009 7570 00	30270070501	80	2"	M16	200	160	18	34
2009 7670 00	30270070601	80	2-1/2"	M16	220	180	18	34
2009 8470 00	30270080401	100	1-1/2"	M16	220	180	18	40
2009 8570 00	30270080501	100	2"	M16	220	180	18	40
2009 8670 00	30270080601	100	2-1/2"	M16	220	180	18	40
2009 9470 00	30270100401	150	1-1/2"	M20	285	240	22	44
2009 9570 00	30270100501	150	2"	M20	285	240	22	44
2009 9670 00	30270100601	150	2-1/2"	M20	285	240	22	44
2009 9770 00	30270100701	150	3"	M20	285	240	22	44

* Above flange material: stainless steel.

*1 piece of flange gasket and 4 pieces of flange bolts(7cm) are attached for DN25/DN40/DN50 /Dn63.

*1 piece of flange gasket and 8 pieces of flange bolts(7cm) are attached for DN80/DN100/DN150



AIRPIPE		Diameter	Rc(Female thread)z	Bolt size	D1	D2	D3	H
Old Part No.	New Part No.							
2009 2279 00	30279020201	25	1"	M12	115	85	14	28
2009 4479 00	30279040401	40	1-1/2"	M16	150	110	18	32
2009 5579 00	30279050501	50	2"	M16	165	125	18	34
2009 6279 00	30279060201	65	1"	M16	185	145	18	32
2009 6479 00	30279060401	65	1-1/2"	M16	185	145	18	32
2009 6579 00	30279060501	65	2"	M16	185	145	18	32
2009 7279 00	30279070201	80	1"	M16	200	160	18	34
2009 7479 00	30279070401	80	1-1/2"	M16	200	160	18	34
2009 7579 00	30279070501	80	2"	M16	200	160	18	34
2009 7679 00	30279070601	80	2-1/2"	M16	220	180	18	34
2009 8479 00	30279080401	100	1-1/2"	M16	220	180	18	40
2009 8579 00	30279080501	100	2"	M16	220	180	18	40
2009 9279 00	30279100201	150	1"	M16	220	180	18	40
2009 9479 00	30279100401	150	1-1/2"	M20	285	240	22	44
2009 9579 00	30279100501	150	2"	M20	285	240	22	44
2009 9679 00	30279100601	150	2-1/2"	M20	285	240	22	44
2009 9779 00	30279100701	150	3"	M20	285	240	22	44

* Above flange material: Carbon steel.

Flexible HOSE

Features

- Compressor outlets (absorption of vibration)
- To bypass obstacles and join to different levels.
- To admit the expansion and contraction of the aluminum pipe.
- Max. working pressure for the flexible hose used for compressed air: 15bar from -20°C ~ $+70^{\circ}\text{C}$.
- Resistant to mineral and synthetic compressor oils.

High pressure Hose

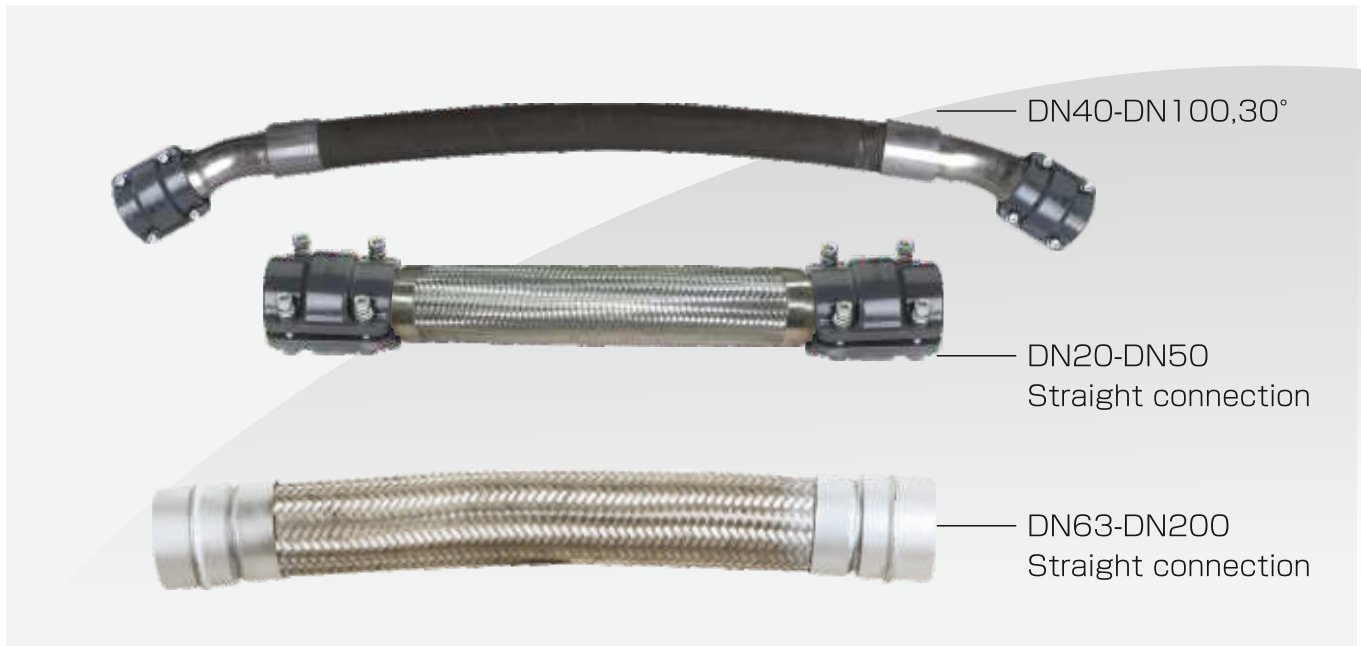

*Warranty 1 Year

AIRPIPE		Nominal Diameter	D mm	L1 inches	L2 inches	Remark
Old Part No.	New Part No.					
AE17 1055 99	30255010004	20	20.1	19.69	22.44	SS304 material, 30°
AE17 2055 99	30255020004	25	25.1	19.69	22.44	
AE17 4055 99	30255040004	40	40.1	19.69	23.62	
AE17 5055 99	30255050004	50	50.1	19.69	23.62	
AE17 4155 99	30255040104	40	40.1	39.37	47.24	SS304 material, 30°
AE17 5155 99	30255050104	50	50.1	43.31	53.15	
2014 6155 00	30155060101	63	67.6	47.24	53.15	Rubber material, 30°
2014 7155 00	30155070101	80	84.8	66.93	72.83	
2014 8155 00	30155080101	100	101.8	66.93	74.80	
2016 6055 00	30155060001	63	67.6	19.69	25.59	SS304 material, Straight connection
2016 7055 00	30155070001	80	84.8	19.69	25.59	
2016 8055 00	30155080001	100	101.8	19.69	25.98	
2017 9055 00	30155100001	150	153	35.43	41.89	
2017 A055 00	30155110001	200	205	55.12	61.18	

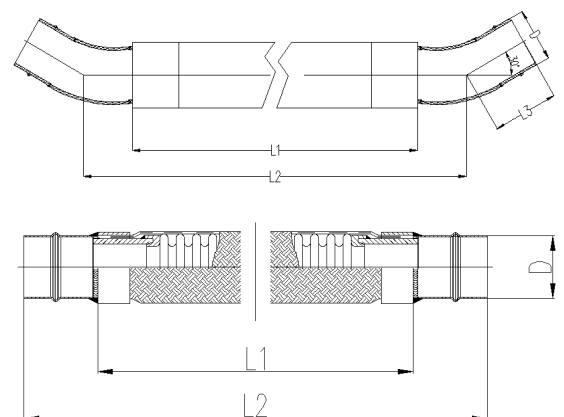

*Two pipe to pipe connectors are needed for the hoses (63mm-200mm)

Fixture Accessories

Features

- Suitable for various piping structure
- Used of installing pipes on well, roof or canals, vertically or horizontally
- Perfectly suitable for AIRPIPE SYSTEM

Flexible pipe clip

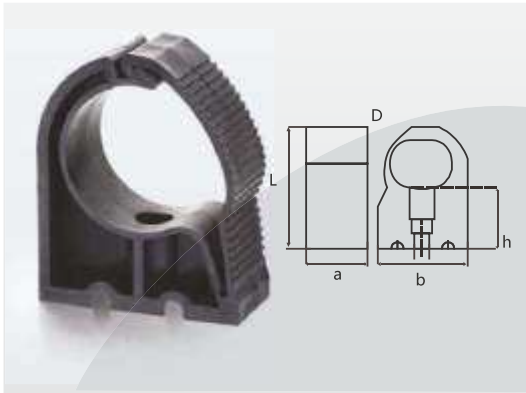

AIRPIPE			D	I	L	H	a	b
Old Part No.	New Part No.							
2009 1022 00	30222010001		20	M8	56	30	30	31
2009 2022 00	30222020001		25	M8	60	27.5	30	38
2009 4022 00	30222040001		40	M8	101	50	40	60
2009 5022 00	30222050001		50	M8	108	45	40	75
2014 6022 00	30222060001		67	M8	118	38.5	40	94
2014 7022 00	30222070001		84	M8	172	71	50	119
2009 8022 00	30222080001		100	M8	209	83	60	162

Pipe Clip Gasket

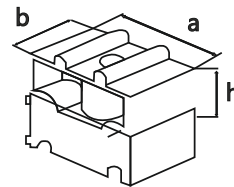

AIRPIPE			D	a	b
Old Part No.	New Part No.				
2009 0027 00	30227000101		20~25	30	49
2009 0127 00	30227000201		40~63	30	94

*Keeping pipe elevation and levelness at the reducer pipe to pipe location.

Fixing Clip/Clip



Fixing Clip

AIRPIPE			D	
Old Part No.	New Part No.			
2014 4122 00	30222040101		40	
2014 5122 00	30222050101		50	1.Used for fixing the two ends of high pressure hose, and 4 pieces of M10 screw nut are attached.
2014 6122 00	30222060101		67	2.Used outdoors (Anti-UV) and compressor room (high intensive).
2014 7122 00	30222070101		84	
2014 8122 00	30222080101		100	

Clip

AIRPIPE			D	
Old Part No.	New Part No.			
2014 9122 00	30222100101		150	*2009 2350 00 for concrete wall
2014 A122 00	30222110101		200	2009 2250/1250 00 for the steel frame 2009 0665/1465/1565 00 for the bracket and grider clamp.

Wall Mounted Bracket

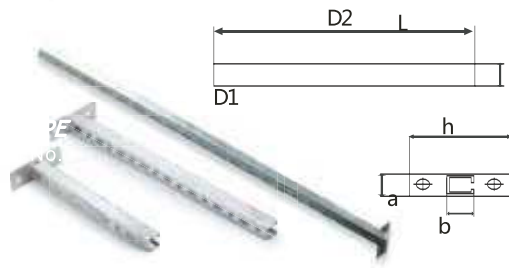

AIRPIPE		L	I	H	a	b
Old Part No.	New Part No.					
2009 0012 00		150	27	120	40	30
2009 0022 00		200	27	120	40	30
2009 0032 00	30132000001	300	27	120	40	30
2009 0132 00	30132000101	500	27	120	40	30
2009 0232 00	30132000201	1200	27	120	40	30

Triangle Bracket

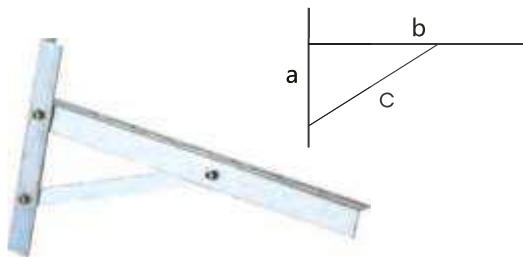

AIRPIPE		a	b	c
Old Part No.	New Part No.			
2012 0632 00	0132000601	300	500	310
2014 0732 00		300	500	310

*Two iron expansions are attached. To support the line above DN150, DN200.

Adjustable Bracket



AIRPIPE		L
Old Part No.	New Part No.	
2009 0432 00	30132000401	1200~2400
2017 0532 00	30132000501	1980

*2009 0432 00 is used for fixing the threaded filter;

2009 0532 00 is used for fixing the flange filter.

*Four iron expansion are attached.

Square Steel

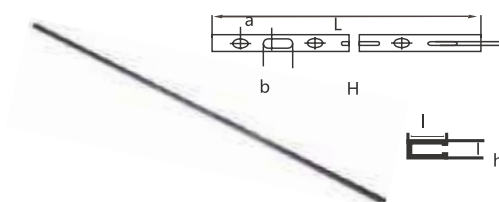

AIRPIPE		L	I	H	h	a	b
Old Part No.	New Part No.						
2009 0230 00	30133000101	300	306	27	11	24	20

*When the square steel is fixed to the concrete pile, the iron expansion 2009 1650 00 is needed.

*Two iron expansion are attached.

Fastener



AIRPIPE		D	I	a	b
Old Part No.	New Part No.				
2009 0037 00	30133000201	70	43	20	4

Knot Tie

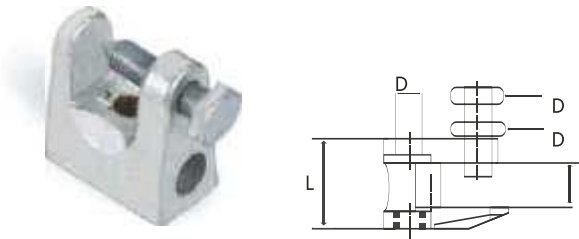

AIRPIPE		D	L	I
Old Part No.	New Part No.			
2009 0433 00	30133000301	M8	36	18

T bolts



AIRPIPE		D	L
Old Part No.	New Part No.		
2009 0665 00	30133000401	M8	50
2009 1465 00	30133000402	M8	60
2009 1565 00	30133000403	M8	70

*The washers are attached.

Threaded Steel Rod



AIRPIPE		D	L	Remark
Old Part No.	New Part No.			
2009 1150 00	30133000601	M8	40	Connecting buckle
2009 1750 00	30133000501	M8	3000	Connecting rod

*Two 8mm screws are attached.

Inner Hexagon Iron Expansion



AIRPIPE		D
Old Part No.	New Part No.	
2012 3750 00	30133000704	12cm

*2012 3750 00 is used for fixing the threaded steel rod to the wall.

Iron Expansion



AIRPIPE		D
Old Part No.	New Part No.	
2009 1550 00	30133000702	M8
2009 1650 00	30133000703	M10

* Used for fixing the wall mounted bracket.

Drilling Tail Screw and Plastic Expansion Screw



AIRPIPE		D	Remark
Old Part No.	New Part No.		
2009 1250 00	30133000802	M5.5x60	Drilling Tail Screw
2009 2250 00	30133000801	M5.5x35	Drilling Tail Screw
2009 2350 00	30133000901	M6x60	Plastic Drilling Tail Screw

Wire Rope



AIRPIPE		D
Old Part No.	New Part No.	
2009 0150 00	30133001002	12

One piece of wire rope shall be requiring 4 wire rope clamp and 2 wire rope knot tie.

Wire Rope turnbuckle



AIRPIPE		D
Old Part No.	New Part No.	
2009 0850 00	30133001102	12

Wire Rope Clamp



AIRPIPE		D
Old Part No.	New Part No.	
2009 0250 00	30133001202	12

Universal Clamp



AIRPIPE		D
Old Part No.	New Part No.	
2009 0135 00	30133001301	25
2009 0235 00	30133001302	50

Beam Suspender



AIRPIPE		L	H	D1	D2
Old Part No.	New Part No.				
2009 0335 00	30133001401	50	25	M6	M8

Cross Fitting



AIRPIPE Part No	DESCRIPTION OF GOODS
30214060001	CROSS FITTING(STAINLESS STEEL) DN63
30214070001	CROSS FITTING(STAINLESS STEEL) DN80
30214080001	CROSS FITTING(STAINLESS STEEL) DN100
30214100001	CROSS FITTING(STAINLESS STEEL) DN150
30214110001	CROSS FITTING(STAINLESS STEEL) DN200

TRANSITION FITTING



AIRPIPE Part No	DESCRIPTION OF GOODS
30299050501	TRANSITION FITTING(T-A) DN50-DN50
30299060601	TRANSITION FITTING(T-A) DN63-DN63
30299070701	TRANSITION FITTING(T-A) DN80-DN80
30299080801	TRANSITION FITTING(T-A) DN100-DN100
30299101001	TRANSITION FITTING(T-A) DN150-DN150

Tool

Tool Box



AIRPIPE		H	L	I
Old Part No.	New Part No.			
2009 0045 00	30145000102	460	330	140

AIRpipe	Component Name	Component Specification	Quantity
301 35 0007 01	Water Pump Pliers	DN20-DN63	1
301 35 0004 01	Hole Deburrer	DN20-DN50	1
301 35 0002 01	Pipe Cutter	DN6-DN63	1
301 35 0003 01	Pipe Deburrer	DN20-DN50	1
301 35 0006 01/02	Drill	ALL	One for each
301 35 0005 01	Drill Clamp	ALL	1
120 44 0005 02	Marker	ALL	1
Maker pen	Marking pen	ALL	1
Allen driver	Allen driver	M3、M5、M6、M8	One for each

* Toolkit is for DN20-DN50 pipeline installation DN63-DN200, other AIRpipe tools are needed.

* For DN80 and DN100 pipe installation, 301 35 0002 03 and 302 44 0001 01 are needed.

* For DN150 and DN200 pipe installation, 301 35 0001 01 and 302 44 0001 01 are needed.

Pipe Cutter Blade



AIRPIPE		DESCRIPTION
Old Part No.	New Part No.	
2009 0240 00	30135000204	DN6-63 Cutter Blade
2009 0340 00	30135000205	DN-63-100 Cutter Blade

Sample Box



AE 15 0146 00

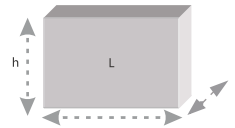

AIRPIPE		H	L	I
Old Part No.	New Part No.			
AE 15 0146 00	30246000101	200	270	190
AE 15 0246 00	30246000204			

Note: About Component of Sample Box, Asking for company Please.

AE 15 0246 00

Pipe Cutting Machine



AIRPIPE		Applicable diameter
Old Part No.	New Part No.	
2015 0344 00	30135000101	DN63-DN200

Aluminum Pipe Cutter



AIRPIPE		L	H	Applicable diameter
Old Part No.	New Part No.			
2009 0040 00	30135000201	220	40	DN6~ DN63
2009 0140 00	30135000203	240	40	DN40-DN110
2009 1140 00				DW100-DW150

Aluminum pipe deburrer



AIRPIPE		L	H	Applicable diameter
Old Part No.	New Part No.			
2009 0141 00	30135000301	90	70	DN12-DN57

Hole Deburrer



AIRPIPE		L	Applicable diameter
Old Part No.	New Part No.		
2009 0042 00	30135000401	160	All Diameter

Drill Arbor & Pilot Bit



AIRPIPE	L	Applicable Drill	Applicable diameter
301 35 0005 01	110	16-25	DN25-DN100
301 35 0005 02	110	38-51	DN150-DN200

Pipe Bender



AIRPIPE		L	Applicable diameter
Old Part No.	New Part No.		
2016 0047 00	30147000101		DN20
2016 0147 00	30147000201		DN25

Pipe Lugging Machine



Manual

AIRPIPE		Normal Diameter	L
Old Part No.	New Part No.		
2014 0544 00	30144000101	DN63-DN200	Manual

Magnetic Drill



AIRPIPE Part No.	Application	Fixing Method
2014 0644 00	used in drilling in steel structure.	fixing with magnetic force

Sizing Chart for Quick Drops

DN (MM)	Quick Drops (PN)					
	2015 2110 99	2015 2011 99	AE15 2110 99			
Φ14	AE18 2110 99	AE18 2210 99	2018 2011 00			
Φ19	2015 4110 99	2015 4210 99	2015 4011 00	2015 4111 00	2015 5110 99	2015 5210 99
	2015 5011 99	2015 5111 99	2015 6110 99	2015 6210 99	2015 6011 00	2015 6111 00
	2015 7110 99	2015 7210 99	2015 7011 00	2015 7111 00	2015 A210 99	
	AE15 4110 99	AE15 4210 99	AE15 5110 99	AE15 5210 99	AE15 6110 99	AE15 6210 99
Φ22	AE15 7110 99	AE15 7210 99	AE15 A210 99			
	AE18 4110 99	AE18 4210 99	2018 4011 00	2018 4111 00		
Φ25	2015 8110 99	2015 8210 99	2015 8011 00	2015 9110 00	2015 9210 99	2015 9011 99
	AE17 8110 99	AE17 8210 99	AE17 9110 99	AE17 9210 99	AE17 8110 99	AE15 8210 99
	AE17 6110 99	AE17 6210 99	2017 6011 00	2017 6111 00	AE15 9110 99	AE15 9210 99
	AE17 7110 99	AE17 7210 99	2017 7011 00	2017 7111 00		
	AE17 5110 99	AE17 5210 99	2017 5011 00	2017 5111 00		
Φ38	AE17 A210 99	2017 8011 99	2017 9011 00			
	2015 8410 99	AE15 8410 99				
Φ51	2015 9410 99	2015 9510 99	2015 A410 99	2015 A510 99		
	AE15 9410 99	AE15 9510 99	AE15 A410 99	AE15 A510 99		

*before drilling, mount the quick drop reversely and mark.Drill to the reverse side of the quick drop at the speed of 650r/m. After drill ,remove the burr and clean up.

Hole Saw Bit



AIRPIPE	L	D	Applicable diameter
301 35 0006 01	50	16	DN25
301 35 0006 02	50	22	DN40
301 35 0006 03	50	25	DN50-DN200
301 35 0006 04	50	38	DN100
301 35 0006 05	50	51	DN150-DN200

Water pump plier



AIRPIPE		Applicable diameter
Old Part No.	New Part No.	
2017 0028 00	30135000701	DN25-DN180

Marker



AIRPIPE		L	Applicable diameter
Old Part No.	New Part No.		
2014 0044 00	12044000501	220	DN25-DN100

Hand-hold lugging machine with charge way



AIRPIPE		Applicable diameter	Drive method
Old Part No.	New Part No.		
AE15 0844 00	30244000101	DN63-DN200	Hydraulic
2017 1844 00	12044000409	DN63-DN200	Jaws of Hydraulic Machine

Installing AIRpipe

General

General

- Prior to the installation of a AIRpipe compressed air distribution system, the installer should ensure that the installation area complies with any regulations applicable to areas exposed to explosive hazards (in particular the effect of static electricity in a silo area). AIRpipe should be installed downstream of the compressed air receiver, or after the dryer. Flexible AIRpipe hose can be installed at the start of the system in order to eliminate any sources of vibration and to facilitate maintenance operations. When maintaining or modifying a AIRpipe system, the relevant section should be vented prior to the commencement of any work. Installers should use only AIRpipe components and accessories, in particular AIRpipe pipe clips and fixture clamps. The technical properties of the AIRpipe components, as described in the AIRpipe catalog, must be respected.
- AIRpipe aluminum pipe is supplied ready for use. No particular preparation (cutting, deburring, chamfering, etc.) is required.
- Thanks to the rigidity of AIRpipe aluminum pipe, temperature-related expansion / contraction is reduced to a minimum. The AIRpipe system retains its straightness, and hence its performance, over time (reduction of pressure drop caused by surface friction).
- AIRpipe aluminum pipe is calibrated and fits perfectly with all AIRpipe components.

Component assembly

- AIRpipe components are provided with assembly instructions for their correct use - simply follow the methods and recommendations stated in this document.

Expansion / contraction

- Expansion and contraction of the system should be calculated prior to installation. The system designer and installer should calculate the elongation or retraction of each AIRpipe line according to the recommendations in this installation guide.

Situations to avoid

- AIRpipe pipe should be protected from mechanical impact, particularly if exposed to collision with fork-lift trucks or when sited in an environment with moving overhead loads. Similarly, rotation of the pipe and pipe supports should be avoided. AIRpipe pipe must not be welded. Flexible AIRpipe hoses should be used in accordance with the recommendations of the installation guidelines.
 - installation within a solid mass (concrete, foam, etc.)
 - the hanging of any external equipment to AIRpipe pipe
 - the use of AIRpipe for grounding, or as a support for electrical equipment
 - exposure to chemicals that are incompatible with AIRpipe components (please contact us for further details)

Best practices to maintain an optimized AIRpipe System

- Design, installation, and maintenance should be performed in accordance with reasonable engineering knowledge and practice with involving piping systems
- Maintain high-quality air levels within your system.
- To avoid pressure drops within your system, minimize pipe diameter reductions
- Properly size your system to allow for optimal flow and efficiency.

Identification

This identification can be done by sticking the adhesive labels directly to the pipe.

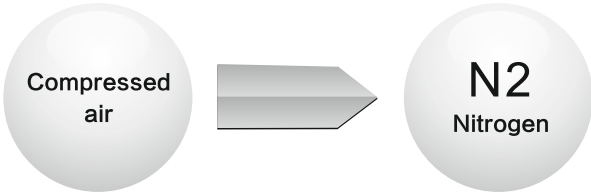

The arrow indicates the direction of the gas flow.

Connection indicator

Prior to the installation, the different size of aluminum pipe (DN20-DN50) need to be marked connection indicator on the surface of the pipe by special marker pen as a reference during connection.

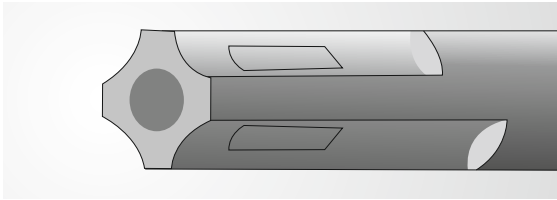

Drilling indicator

There is one locators on each pipe .they can ensure the correct position during drilling more hole on the pipe.

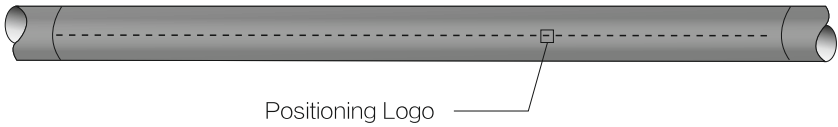

Cutting the PIPE

Rotate the corresponding pipe cutter around the pipe while gently tightening the wheel.

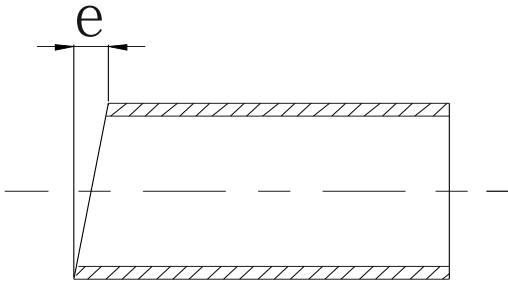

Nominal Diameter	Cutting slope of pipe end allowable deviation (e)
20-80	1.0
100-150	1.4
200	2.0

Using the Cutter 301 35 0002 01 for DN20~DN63;
Using the Cutter 301 35 0001 01 for DN63~DN200

Fixing and supporting for AIRpipe network

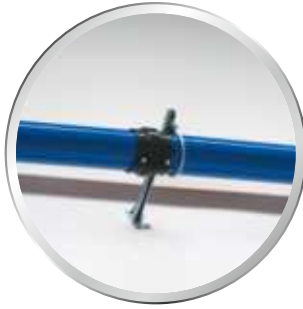

01 Iron expansion is needed when fixing the tube clip on the wall, All AIRpipe tube clip are fixed with M8 screw.



02 For small diameter (DN20~DN80), girder clamp (301 33 0003 01) is used for the steel beam.



03 The cantilever bracket (301 32 0000 01 and 301 32 0000 01, the length of cantilever :30cm and 50cm) can be used when installation position is further away from the wall.

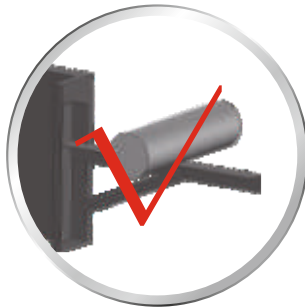

04 For large diameter (DN100~DN200), welding could be used for the steel beam.

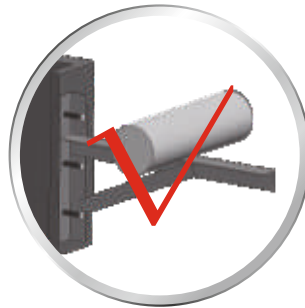

05 For large diameter (DN100~DN200), drilling could be used for the steel beam.

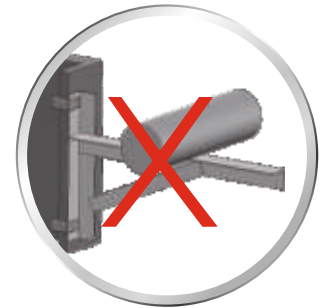

06 For large diameter (DN100~DN200), girder clamp can't be used for the steel beam (Insufficient Rigidity).

AIRpipe Suitable Range

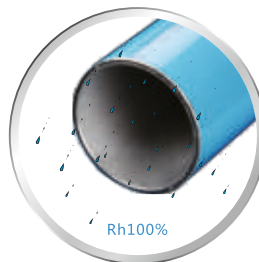
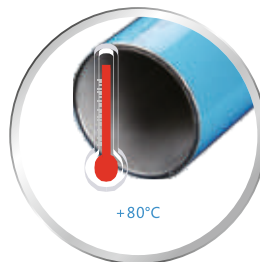
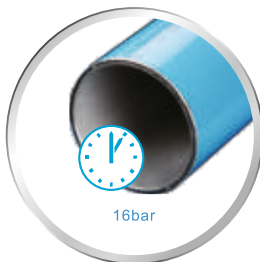

Following actions are not allowed during the installation of AIRpipe aluminum pipe.

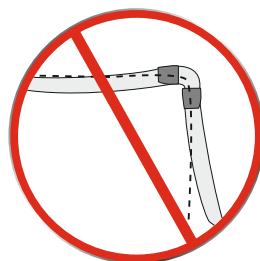
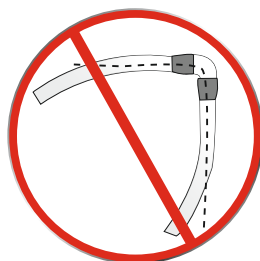
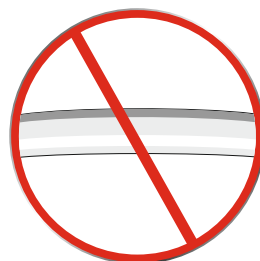

Superior Reliability!

Quick and Easy Installation



Sizing Chart for Quick Drops

Pilot Bit	Hole Saw	DN(MM)	Quick Drops (PN)						
30135000501	30135000606	Φ16	30210020104	30210020203	30210020203				
30135000501	30135000607	Φ22	30210040104	30210040204	30211040003	30211040103			
30135000501	30135000603	Φ25	30210050101	30210050201	30210060101	30210060201	30210070101	30210070201	
			30210080101	30210080201	30210100101	30210100201	30210110201		
			30211050001	30211050101	30211060001	30211060101	30211070001	30211070101	
			30211080001	30211100001					
30135000502	30135000604	Φ38	30210080401						
30135000502	30135000605	Φ51	30210100401	30210100501	30210110401	30210110501			

Insertion Depth S For DN20~DN50 Connector

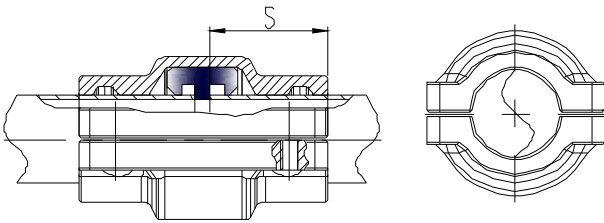

DN	Insertion depth S (IN)mm
20	29mm
25	29mm
40	39mm
50	39mm

- "S" denotes the insertion depth of the pipe into the connector.

Installation Guide for DN20~DN50

- 01** Mark the pipe with a marker pen as shown below :

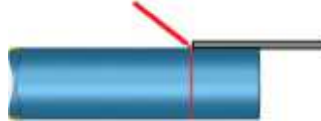

- 02** Insert the marked pipe into the connector :

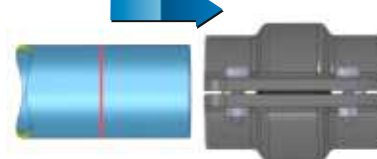

- 04** A portion of the marked lines should remain visible after the pipe is inserted into the connector.



- 03** Bring the second pipe to the connector and slide up to the marked insertion depth



- 05** Tighten the pre-fitted screws. Flush the clamshell halves together to complete assembly

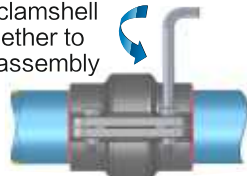

- 06** Tighten the screws in an "X" pattern. To disassemble, perform the same operation in reverse order.

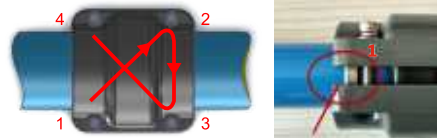

Deburr The Outer and Inner Edges Before Installation

- Use 301 35 0003 01 for DN20-DN50 to deburr the outer edges and also deburr the inner end.

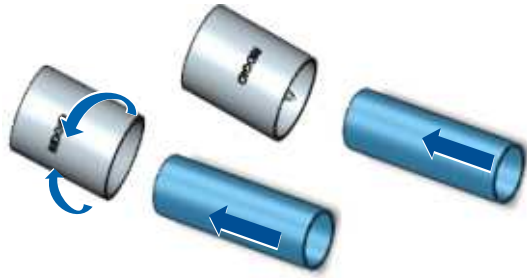

- Use a file for DN63-DN200 to chamfer the outer edges ; make use of a deburring tool to deburr the inside of the pipe end.



Installation Guide for DN63~DN200

01

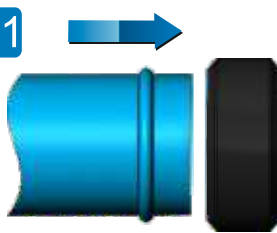

Slide the seal over the edge of the pipe so that it sits flush with the lugged edge.



02

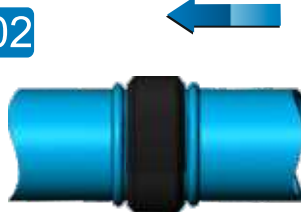

Insert the second pipe into the seal until the seal and the lugged edge are flush.



03

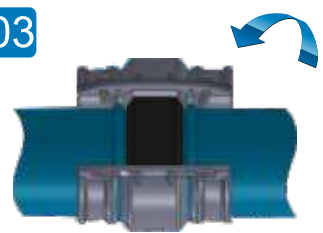

Position the clamshell over the seal.



04

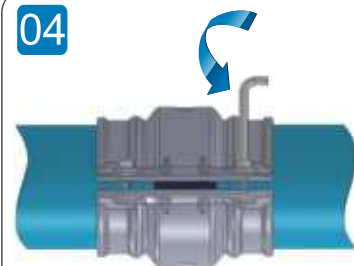

Tighten the pre-fitted screws.



05

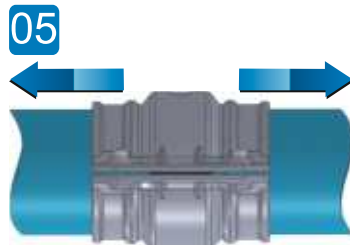

Pull the pipe back towards the outside of the clamshell to complete alignment.



06

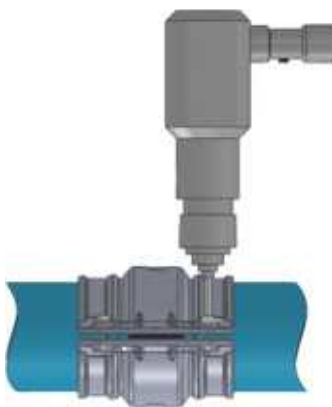

Tighten the pre-fitted screws. Flush the clamshell halves together to complete assembly



07

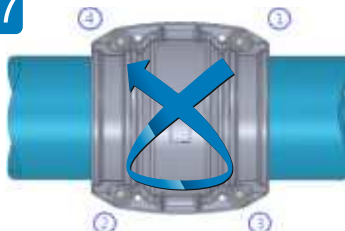

For effective assembly, tighten the screws in an "X" pattern. To disassemble, perform the same operation in reverse order.

Hand-held hydraulic lugging machine operation requirements



Manually open the jaws of the clamp and insert the aluminum pipe into the clamp as far as possible.



Release the jaws. Press the trigger and crimp the pipe until a "snap" sound is heard.

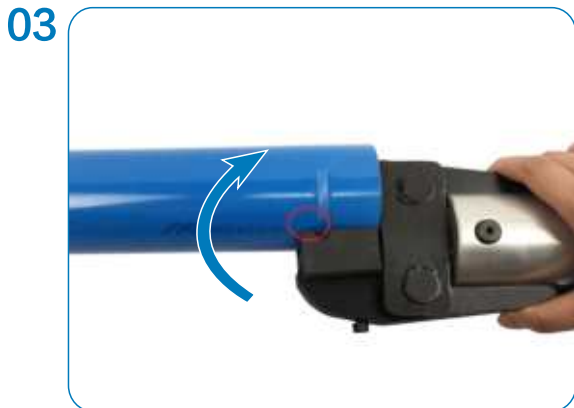

Re-open the two jaws to remove the pipe and rotate the pipe slightly. Put the jaw side to the mark position.

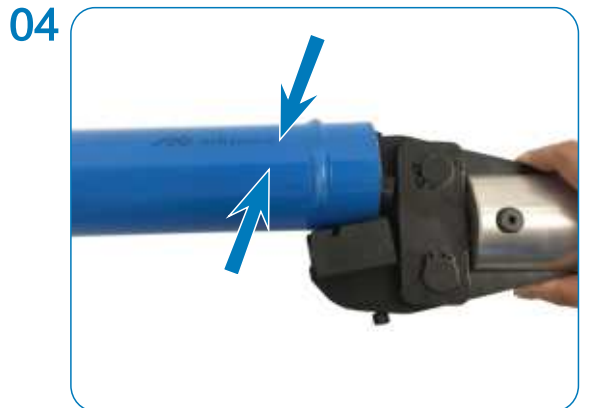

Renew the operation until the required minimum number of lugs for each diameter is finished.

Hand-held hydraulic lugging machine operation requirements

AIRPIPE	DN63	DN80	DN100	DN150	DN200
Min. number of lugs	5	6	6	9	12

Note: Do not overlap the lugs!

Lugs size for DN63~DN200

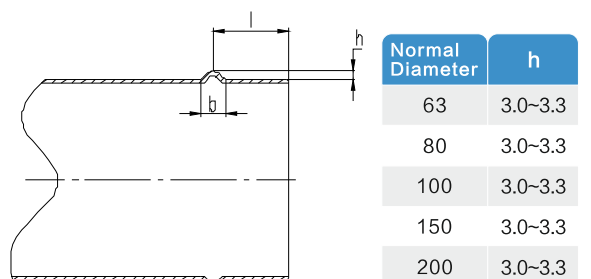

Pipe Clip

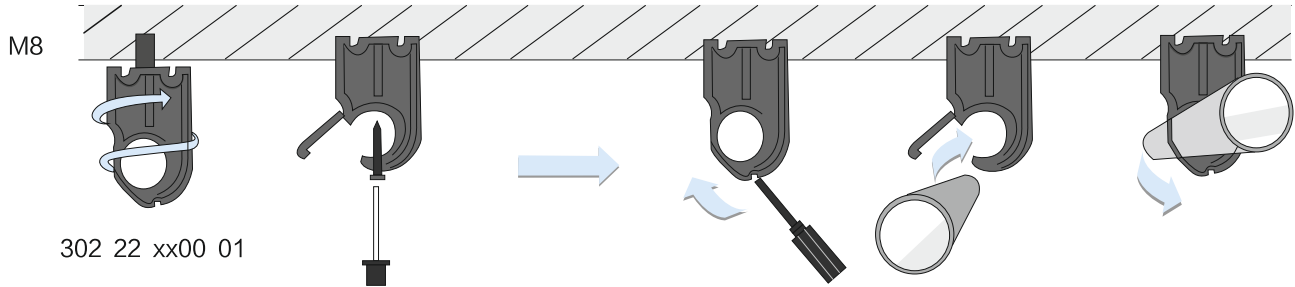

AIRpipe's pipe clips are designed for versatility. They can be secured via all-thread rod through the clips internal M8 nut, or mounted directly with wall anchors.

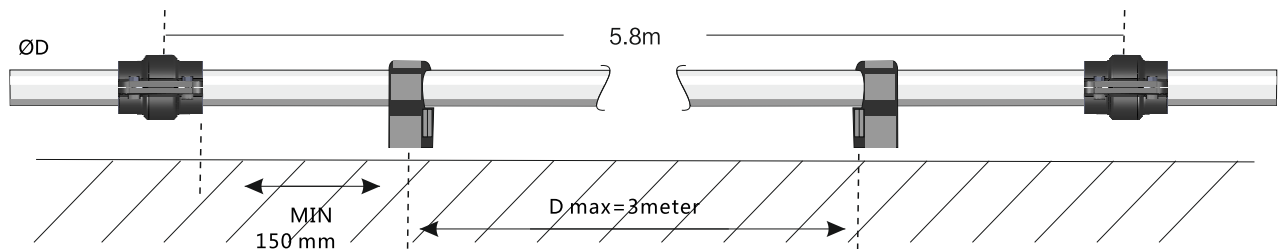

The bolt size M8 is suitable for all fixing clips.

This clip allows expansion and contraction of the pipe to occur freely. The fixing clip should be fixed at the min distance of 150mm from the connector in order to allow for the expansion and contraction effect.

Spacers for pipe clips

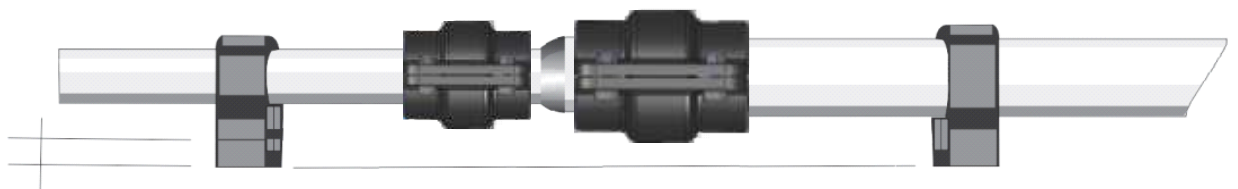

302 27 0001 01
 Ø20-25 mm/ $3/4$ "-1"



302 27 0002 01
 Ø40-63 mm/ $1\frac{1}{2}$ "-2 $\frac{1}{2}$ "

Spacer clip 302 27 0001 01 is used to create a level plane for DN20 or DN25 diameters transitioning to DN40, DN50 or DN63. Spacer clip 302 27 0002 01 is used to create a level plane for DN40, DN50 or DN63 diameters transitioning to DN80 or DN100.

Installing Quick Drop Connectors

01



- Mark the pipe where the hole for the quick drop connector will be installed.

02



- Identify the drill arbor & hole saw bit required by locating the quick drop part number on the sizing chart. Note: the quick drop part number is located on the connector.

03



- With the proper drill arbor & hole saw bit part numbers identified, thread the hole saw bit onto the drill arbor to create a single drill bit.

04



- Hold the drill perpendicular to the pipe with the drill bit in the center of the mark placed on the pipe.

05



- Apply steady pressure until the hole saw bit has completely entered the pipe.

06



- Remove debris and deburr cut edges.

07



- The quick drop connector easily aligns into the drilled hole.

08



- Tighten the bolt to complete assembly

Compensating for the effect of expansion and contraction due to temperature variations

Consequences of not properly accounting for thermal variations:

- Leakage and system deformation, that in extreme situations, could result in a connection separation.
 - Pipe system movement could create an obstruction.
 - Quick drop connections could become compromised.
1. In order to compensate for the effects of expansion and contraction due to temperature variations, system lengths should be appropriately evaluated and expansion joints installed where needed.
 - a. Anytime there is a change in temperature between areas.
 - b. For significant lengths of piping.
 2. Recommended locations of flexible hoses or expansion loops include but are not limited to.
 - a. The discharge of the compressor.
 - b. The middle of a long run of pipe.
 - c. Corners of a piping network.
 - d. In a multiple loop at the beginning of a parallel line internal to the pipeline loop.
 3. Best practices include but are not limited to:
 - a. All aluminum piping to be installed in strict accordance with AIRpipe installation instructions and specifications .
 - b. Allowing the corners to expand and contract by placing pipe clips an appropriate distance from each corner. Avoid placing a pipe clip directly in the corner.
 - c. Install piping indicated to be exposed and piping in equipment rooms and service areas at right angles or parallel to building walls.
 - d. Install piping adjacent to equipment and machines to allow service and maintenance.
 - e. Install air and drain piping with 1 percent slope downward in direction of flow.
 - f. Install nipples, flanges, unions, transition, and special fittings, and valves with pressure ratings same as or higher than system pressure rating, unless otherwise indicated.
 - g. Install branch connections to compressed-air mains from top of main. Provide drain leg and drain trap at end of each main and branch and at low points.
 - h. Install piping to permit valve servicing.
 - i. Install piping free of sags and bends.
 - j. Install sleeves and escutcheons for piping penetrations of walls, ceilings, and floors as necessary.
 - k. The fixing clips shall allow axial movement of the pipe to compensate for system expansion and contraction.
 - l. Horizontal and vertical AIRpipe piping shall be supported by AIRpipe pipe clips. Hangers to be spaced at intervals as described herein, as required to avoid sag, prevent vibration, and allow accurate leveling or grading.

Number	ΔT (°C)	Reference table: Allowable max. installation distance L (meters)								
		DN20	DN25	DN40	DN50	DN63	DN80	DN100	DN150	DN200
1	20°C	The pipe can prolong itself	The pipe can prolong itself	120	120	110	105	95	80	75
2	25°C			115	115	105	100	90	75	70
3	30°C			110	110	100	95	85	70	65
4	35°C			100	100	90	90	80	65	60
5	40°C			90	90	85	75	70	60	55

• ΔT = System Temperature - Room Temperature

A1) Single loop pipeline for DN40-DN100

* Use 30° flexible hose in the middle of pipeline

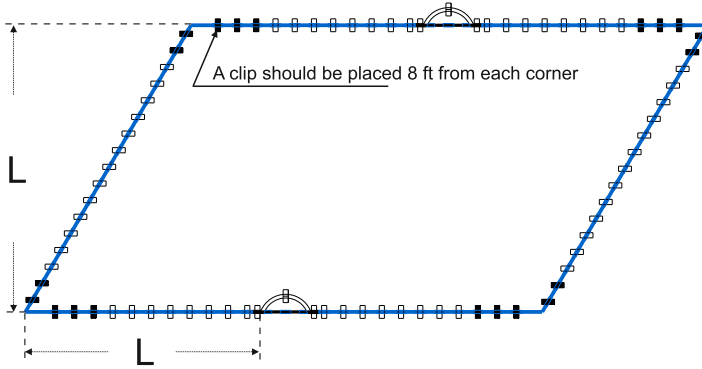

A2) Multiloop pipeline for DN40-DN100

* Use 30° flexible hose in the middle of pipeline

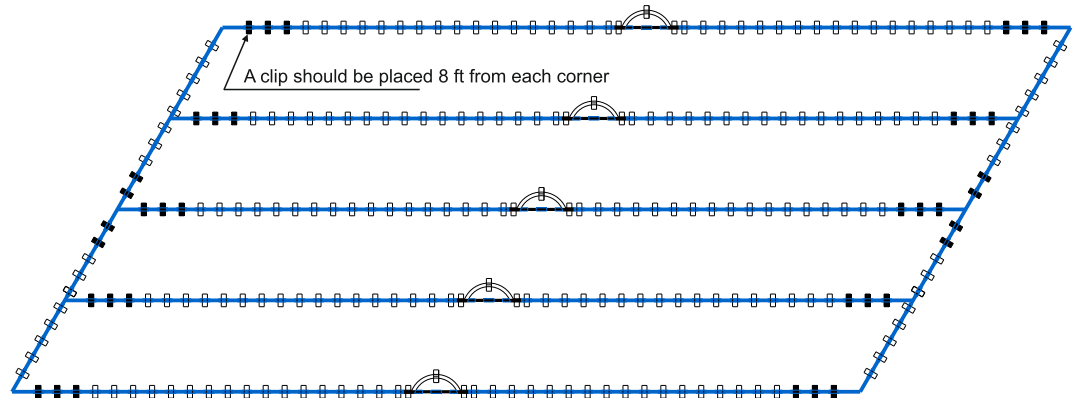

B1) Single loop pipeline for DN150-DN200

* Use two metal hoses in the middle of pipeline

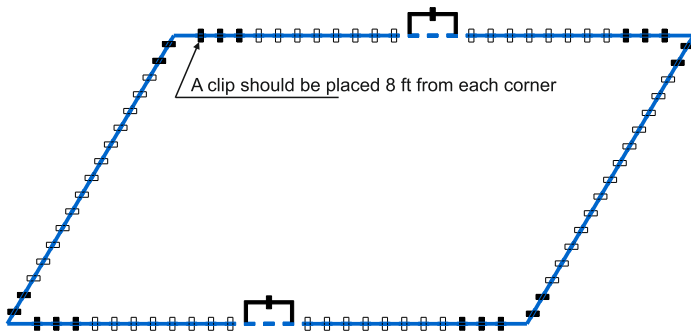

B2) Multiloop pipeline for DN150-DN200

* Use two metal hoses in the middle of pipeline

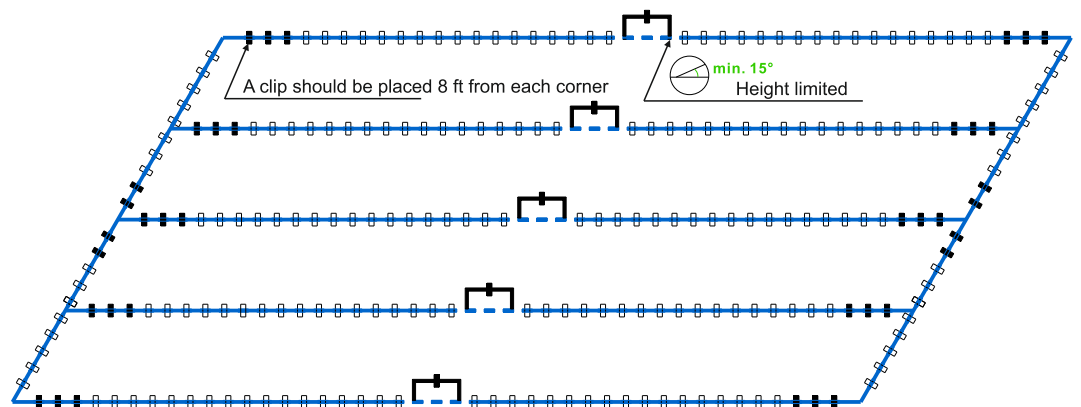

Rubber Seals

AIRPIPE Item No.	Seal No.	Description
30210020115	12090020304	QUICK DROP: 25.1 X 20.1 MM
30210020214	12090020304	QUICK DROP: 25.1 X 25.1 MM
30210030111	12090030303	QUICK DROP: 32.2 X 20.1 MM
30210040115	12090040304	QUICK DROP: 40.1 X 20.1 MM
30210040215	12090040304	QUICK DROP: 40.1 X 25.1 MM
30210050111	12090050303	QUICK DROP: 50.1 X 20.1 MM
30210050211	12090050303	QUICK DROP: 50.1 X 25.1 MM
30210060110	12090060304	ALU. QUICK DROP: 67.6 X 20.1 MM
30210060210	12090060304	ALU. QUICK DROP: 67.6 X 25.1 MM
30210070110	12090070304	ALU. QUICK DROP: 84.8 X 20.1 MM
30210070210	12090070304	ALU. QUICK DROP: 84.8 X 25.1 MM
30210080116	12090080305	ALU. QUICK DROP: 101.8 X 20.1 MM
30210080216	12090080305	ALU. QUICK DROP: 101.8 X 25.1 MM
30210100116	12090100305	ALU. QUICK DROP: 153.0 X 20.1 MM
30210100216	12090100305	ALU. QUICK DROP: 153.0 X 25.1 MM
30210110210	12090110305	ALU. QUICK DROP: 205.0 X 25.1 MM
30202060105	30160060004	ALU. EQUAL CONNECTOR: 67.6 MM
30202070108	30160070004	ALU. EQUAL CONNECTOR: 84.8 MM
30202080108	30160080004	ALU. EQUAL CONNECTOR: 100.8 MM
30202100105	30160100004	ALU. EQUAL CONNECTOR: 153.0 MM
30202110105	30160110004	ALU. EQUAL CONNECTOR: 205.0 MM
30210080404	12090080306	ALU. QUICK DROP: 101.8 X 40.1 MM
30210100404	12090100306	ALU. QUICK DROP: 153.0 X 40.1 MM
30210100504	12090100306	ALU. QUICK DROP: 153.0 X 50.1 MM
30210110404	12090110306	ALU. QUICK DROP: 205.0 X 40.1 MM
30210110504	12090110306	ALU. QUICK DROP: 205.0 X 50.1 MM
30211020004	12090020304	QUICK DROP: 25.1 X 1/2" FEMALE
30211030003	12090030303	QUICK DROP: 32.2 X 1/2" FEMALE
30211040004	12090040304	QUICK DROP: 40.1 X 1/2" FEMALE
30211040104	12090040304	QUICK DROP: 40.1 X 3/4" FEMALE
30211050004	12090050303	QUICK DROP: 50.1 X 1/2" FEMALE
30211050104	12090050303	QUICK DROP: 50.1 X 3/4" FEMALE
30211060003	12090060304	QUICK DROP: 67.6 X 1/2" FEMALE
30211060103	12090060304	ALU. QUICK DROP: 67.6 X 3/4" FEMALE
30211070003	12090070304	ALU. QUICK DROP: 84.8 X 1/2" FEMALE
30211070103	12090070304	ALU. QUICK DROP: 84.8 X 3/4" FEMALE
30211080004	12090080305	ALU. QUICK DROP: 100 X 1/2" FEMALE
30211100004	12090100305	ALU. QUICK DROP: 150 X 1/2" FEMALE



Pneumatic Accessories



*Warranty 1 year

Pressure Meter



AIRPIPE		D	Remark
Old Part No.	New Part No.		
2009 0483 00	30134000101	1/2" Male thread	Shock resistance, 0-1.6MPa, 1.6 degree, the shock absorbing pipe is attached.
2009 0583 00	30134000102	1/2" Male thread	Non-Shock resistance, 0-1.6MPa, 1.6 degree, .
2009 0683 00	30134000103		1/2" Female thread-1/2" Male thread, Brass shock absorbing .

Automatic Drain Valve



AIRPIPE		Inlet size	PN
Old Part No.	New Part No.		
2009 0973 00	30134000201	1/2" Female thread	16Bar

*One ball valve is needed before using this drain valve.

Electronic Drain Valve



AIRPIPE		Inlet size	PN
Old Part No.	New Part No.		
2009 0873 00	30134000301	1/2"	16Bar

*One ball valve is needed before using this drain valve.

Atmolysis Bag



<i>AIRPIPE</i>		L	D1	D2	D3
Old Part No.	New Part No.				
2016 1085 00	30185000101	200	¾"Male Thread	½"Male Thread	½"Female Thread
2016 2085 00	30185000201	300	¾"Male Thread	½"Male Thread	½"Female Thread
2016 3085 00	30185000301	400	¾"Male Thread	½"Male Thread	½"Female Thread

Pneumatic Fittings



<i>AIRPIPE</i>		D	Connection Port	
Old Part No.	New Part No.			
40SMT	60103000005	½"	Male Thread	One-way connection
SMVA-P	60103000019	½"	Male Thread	Two-way connection
SMYA-P	60103000022	½"	Male Thread	Three-way connection
SMMA-P	60103000025	½"	Male Thread	Four-way connection

PU HOSE



PART NO's	ID	OD	MTR	DES.
IAP HUS2504	2.5	4	200M	PU TUBE
IAP HUS0406	4	6	200M	PU TUBE
IAP HUS0508	5	8	100M	PU TUBE
IAP HUS6510	6.5	10	100M	PU TUBE
IAP HUS0812	8	12	100M	PU TUBE
IAP HUS1014	10	14	50M	PU TUBE
IAP HUS1216	12	16	50M	PU TUBE
IAP HUS95135	9.5	13.5	50M	PU TUBE
IAP HUB0508	5	8	100M	PU BRAID AIR HOSE
IAP HUB6510	6.5	10	100M	PU BRAID AIR HOSE
IAP HUB0812	8	12	100M	PU BRAID AIR HOSE
IAP HUB1014	10	14	50M	PU BRAID AIR HOSE
IAP HUB1216	12	16	50M	PU BRAID AIR HOSE
IAP HUB95135	9.5	13.5	50M	PU BRAID AIR HOSE

PU RECOILED AIR TUBE



PART NO's	ID	OD	MTR	DES.
IAP HUBR0508-5	5	8	5M	PU BRAID FLEXIBLE AIR TUBE
IAP HUBR0508-10	5	8	10M	PU BRAID FLEXIBLE AIR TUBE
IAP HUBR0508-15	5	8	15M	PU BRAID FLEXIBLE AIR TUBE
IAP HUBR6510-5	6.5	10	5M	PU BRAID FLEXIBLE AIR TUBE
IAP HUBR6510-10	6.5	10	10M	PU BRAID FLEXIBLE AIR TUBE
IAP HUBR6510-15	6.5	10	15M	PU BRAID FLEXIBLE AIR TUBE
IAP HUBR0812-5	8	12	5M	PU BRAID FLEXIBLE AIR TUBE
IAP HUBR0812-10	8	12	10M	PU BRAID FLEXIBLE AIR TUBE
IAP HUBR0812-15	8	12	15M	PU BRAID FLEXIBLE AIR TUBE
IAP HUBR95135-5	9	13.5	5M	PU BRAID FLEXIBLE AIR TUBE
IAP HUBR95135-10	9	13.5	10M	PU BRAID FLEXIBLE AIR TUBE
IAP HUBR95135-15	9	13.5	15M	PU BRAID FLEXIBLE AIR TUBE
IAP HUBR1014-5	10	14	5M	PU BRAID FLEXIBLE AIR TUBE
IAP HUBR1014-10	10	14	10M	PU BRAID FLEXIBLE AIR TUBE
IAP HUBR1014-15	10	14	15M	PU BRAID FLEXIBLE AIR TUBE

AIR HOSE REEL



PART NO.	HOSE SIZE (mm)	LENGTH (M)	HOSE COLOR	HOSE
IAP HR01050810U	5X8	10	BLUE	PU Braid Hose
IAP HR01050812U	5X8	12	BLUE	PU Braid Hose
IAP HR01651010U	6.5X10	10	BLUE	PU Braid Hose
IAP HR01081208U	8X12	8	BLUE	PU Braid Hose



PART NO.	HOSE SIZE (mm)	LENGTH (M)	HOSE COLOR	HOSE
IAP HR0608 1230U-BD	8X12mm	30	BLUE	PU Braid Hose
IAP HR0665 1030U-BD	6.5X10mm	30	BLUE	PU Braid Hose

AIR GUNS



B-90

B-91

B-93

► Specification

PART NO.	PORT SIZE	NOZZLE LENGTH	NOZZLE OD	MAX. PRESSURE	AIR FLOW
IAP B90	1/4" G	5CM	≈ 8mm	15Bar (213psi/1.5Mpa)	1200L/M @150psi
IAP B91		25CM			
IAP B93		12CM			

► Features

- ① Steel reinforced inlet.
- ② Light weight and durable.
- ③ High flow: flow higher than standard >1200L/M@150PSI.
- ④ Long life time: top-down valve structure design, less wear of spring, longer lifetime.

AIR GUNS

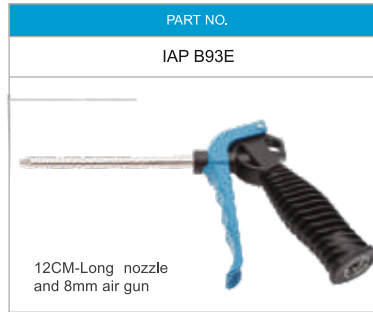

Part Number	Description			
IAP B90-G	1/4"G	5CM	Φ 8	AIR GUN
IAP B91-G	1/4"G	25CM		AIR GUN
IAP B93-G	1/4"G	12CM		AIR GUN
IAP B90C-07-G	1/4"G	LOW NOISE		AIR GUN
IAP B90C-12-G	1/4"G	CENTRALIZED NOZZLE		AIR GUN
IAP B90C-14-G	1/4"G	ADJUSTABLE NOZZLE		AIR GUN
IAP B90C-20-G	1/4"G	HIGH FLOW NOZZLE		AIR GUN
IAP B93C-G WITH JOINT	1/4"G	12CM	Φ 8	AIR GUN
IAP B90E-G	1/4"G	RUBBER NOZZLE		AIR GUN
IAP B61-G	3/8"G			HIGH FLOW AIR GUN
IAP B60-G	3/8"G	LOW NOISE		HIGH FLOW AIR GUN
IAP B60A-G	3/8"G	ADJUSTABLE NOZZLE		HIGH FLOW AIR GUN
IAP B60B-G	3/8"G	CENTRALIZED NOZZLE		HIGH FLOW AIR GUN
IAP B60C-G	3/8"G	HIGH FLOW NOZZLE		HIGH FLOW AIR GUN



Part Number	Filter, Regulator & Lubricator
IAP FRL 502 - G	TWO SECTION AIR UNIT 1/4" G
IAP FRL 503 - G	TWO SECTION AIR UNIT 3/8" G
IAP FRL 504 - G	TWO SECTION AIR UNIT 1/2" G
IAP FRL 908 - G	TWO SECTION AIR UNIT 1" G



Part Number	Filter & Regulator
IAP FR 502 - G	TWO SECTION AIR UNIT 1/4" G
IAP FR 503 - G	TWO SECTION AIR UNIT 3/8" G
IAP FR 504 - G	TWO SECTION AIR UNIT 1/2" G
IAP FR 908 - G	TWO SECTION AIR UNIT 1" G

Coupler

SM Socket Male : CS - Carbon Steel

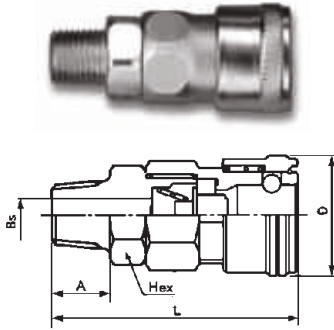

PART NO SS	L (mm)	D (mm)	Hex (mm)	A (mm)	Bs (mm)
IAP20SM CS	Rc1/4"	55.5	Hex.19	13.0	7
IAP30SM CS	Rc3/8"	56.5	Hex.19	14.0	8
IAP40SM CS	Rc1/2"	59.5	Hex.24	16.0	9
IAP600SM CS	Rc3/4"	67.0	Hex.32	19.0	16
IAP800SM CS	Rc1"	72.0	Hex.36	22.0	16

PM Plug Male : CS - Carbon Steel

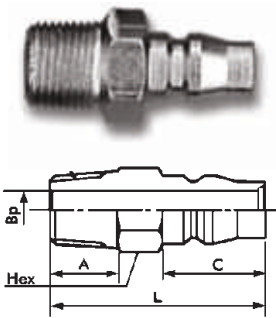

PART NO CS	APPLICATION	L (mm)	A (mm)	Hex (mm)	C (mm)	Bp (mm)
IAP20PM CS	Rc1/4"	41.0	13	Hex.14	20	7.5
IAP30PM CS	Rc3/8"	42.0	14	Hex.19	20	7.5
IAP40PM CS	Rc1/2"	46.0	16	Hex.22	20	12.0
IAP600PM CS	Rc3/4"	55.0	18	Hex.32	23	19.0
IAP800PM CS	Rc1"	63.0	22	Hex.35	23	22.0

SF Socket Female : CS - Carbon Steel

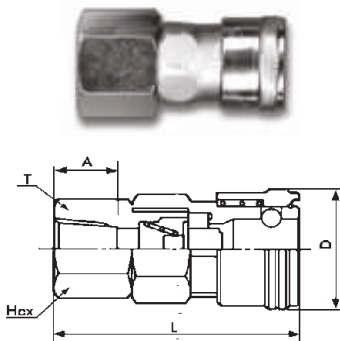

PART NO CS	APPLICATION	L (mm)	D (mm)	Hex (mm)	A (mm)	T
IAP20SF CS	Rc1/4"	49.5	26.5	Hex.19	13.0	Rc1/4"
IAP30SF CS	Rc3/8"	50.5	26.5	Hex.21	14.0	Rc3/8"
IAP40SF CS	Rc1/2"	52.5	26.5	Hex.29	15.0	Rc1/2"
IAP600SF CS	Rc3/4"	61.0	35.0	Hex.35	17.0	Rc3/4"
IAP800SF CS	R1"	68.0	35.0	Hex.41	22.0	Rc1"

PF Plug Female : CS - Carbon Steel

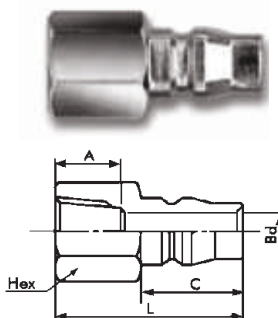

PART NO CS	APPLICATION	L (mm)	A (mm)	Hex (mm)	C (mm)	Bd (mm)
IAP20PF CS	R1/4"	36.0	13	Hex.17	20	7.5
IAP30PF CS	R3/8"	37.0	14	Hex.21	20	7.5
IAP40PF CS	R1/2"	38.0	15	Hex.29	20	7.5
IAP600PF CS	R3/4"	45.0	17	Hex.35	23	13.0
IAP800PF CS	R1"	54.0	22	Hex.41	23	13.0

SH Socket Hose : CS - Carbon Steel

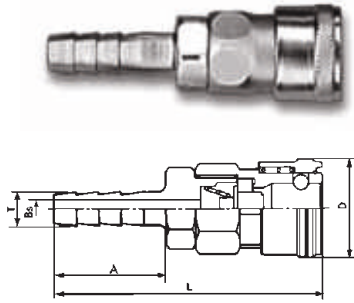

PART NO CS	APPLICATION	L (mm)	D (mm)	A (mm)	T (mm)	Bs (mm)
IAP20SH CS	For 1/4" Hose	72.5	26.5	30	9.0	5.0
IAP30SH CS	For 3/8" Hose	76.5	26.5	34	11.3	7.5
IAP40SH CS	For 1/2" Hose	78.5	26.5	36	15.0	9.0
IAP600SH CS	For 3/4" Hose	92.0	35.0	45	21.0	14
IAP800SH CS	For 1" Hose	102.0	35.0	55	27.0	16

PH Plug Hose : CS - Carbon Steel

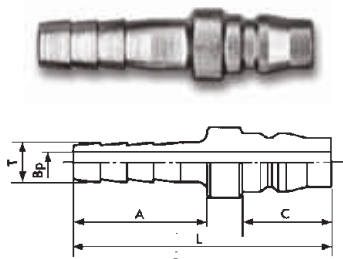

PART NO CS	APPLICATION	L (mm)	A (mm)	C (mm)	T (mm)	Bp (mm)
IAP20PH CS	For 1/4" Hose	57.0	30	20	9.0	5.0
IAP30PH CS	For 3/8" Hose	61.0	34	20	11.3	7.5
IAP40PH CS	For 1/2" Hose	63.0	36	20	15.0	7.5
IAP600PH CS	For 3/4" Hose	77.0	45	23	21.0	13.0
IAP800PH CS	For 1" Hose	85.0	54	23	27.0	20.0

SN Nut Socket : CS - Carbon Steel | Chrome Plated

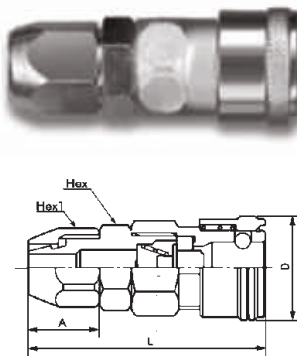

PART NO CS	APPLICATION	L (mm)	A (mm)	D (mm)	Hex (mm)	Hex1 (mm)
IAP50SN CS	8X5.5 Hose	60.0	17	26.5	Hex. 19	Hex. 19
IAP65SN CS	10X6.5 Hose	59.5	17	26.5	Hex. 19	Hex. 19
IAP80SN CS	12X8 Hose	61.5	19	26.5	Hex. 19	Hex. 19
IAP110SN CS	16X12 Hose	64.5	23	26.5	Hex. 23	Hex. 23
IAP100SN CS	14X10 Hose					

PN Nut Plug : CS - Carbon Steel | Chrome Plated

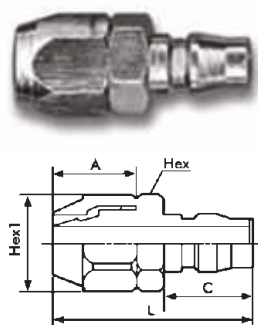

PART NO CS	APPLICATION	L (mm)	A (mm)	C (mm)	Hex (mm)	Hex1 (mm)
IAP50PN CS	8X5.5 Hose	43.0	17	20	Hex. 17	Hex. 17
IAP65PN CS	10X6.5 Hose	43.0	17	20	Hex. 17	Hex. 17
IAP80PN CS	12X8 Hose	45.0	19	20	Hex. 19	Hex. 19
IAP110PN CS	16X12 Hose	52.0	23	20	Hex. 23	Hex. 23
IAP100PN CS	14X10 Hose					

AIRPIPE DIAMETER SELECTION

AIRPIPE Selection Chart

Flow cub feet /min	Flow Nm ³ /h	Length									
		50M	100M	150M	300M	500M	750M	1000M	1300M	1600M	2000M
6	10	20	20	20	20	20	20	20	20	20	20
18	30	20	20	20	20	20	20	20	25	25	25
30	50	20	20	20	20	25	25	25	25	25	40
41	70	20	20	20	25	25	25	40	40	40	40
59	100	20	20	25	25	40	40	40	40	40	40
88	150	20	25	25	40	40	40	40	40	40	40
147	250	25	40	40	40	40	40	50	50	50	50
206	350	40	40	40	40	50	50	50	50	63	63
294	500	40	40	40	50	50	50	63	63	63	63
441	750	40	40	50	50	63	63	63	63	63	80
588	1000	40	50	50	63	63	63	63	80	80	80
736	1250	50	50	63	63	63	80	80	80	80	80
883	1500	50	50	63	63	63	80	80	80	80	100
1030	1750	50	63	63	63	80	80	80	100	100	100
1177	2000	50	63	63	80	80	80	100	100	100	100
1471	2500	63	63	63	80	80	100	100	100	100	150
1766	3000	63	63	80	80	100	100	100	150	150	150
2060	3500	63	63	80	80	100	100	150	150	150	150
2354	4000	63	80	80	100	100	150	150	150	150	150
2649	4500	63	80	80	100	100	150	150	150	150	150
2942	5000	63	80	80	100	150	150	150	150	150	150
3237	5500	80	80	80	100	150	150	150	150	150	150
3531	6000	80	80	100	100	150	150	150	150	150	150
3826	6500	80	80	100	150	150	150	150	150	150	150
4238	7200	80	100	100	150	150	150	150	150	150	200
4709	8000	80	100	100	150	150	150	150	150	150	200
5002	8500	80	100	100	150	150	150	150	150	200	200
5886	10000	80	100	150	150	150	150	150	200	200	200
7063	12000	100	150	150	150	150	150	200	200	200	200

- Closed loop system at 8bar with 5% allowable pressure drop.





AIRpipe Manufacturing Plant



AIRpipe complies with FDA EC standards for FOOD



**1935/2004, Food Contact
Materials Regulation in EU**



**FDA CFR 21, GRAS, Food and
Drugs Regulation in US**



www.airpipe.in

Head Office :

Instamod Air Pipe Pvt. Ltd.
709, Shahpuri Tower, C-58, Janakpuri,
New Delhi - 110058. Tel : 011- 49535588, 41755588
Email : sales@airpipe.in, santosh.kumar@airpipe.in

Branch Office :

SF. No. 106/2L1,
Thannam Nagar, Karayapalayam,
Sulur Coimbatore - 641062
E-mail : south1@airpipe.in